



**ONLINE RTX1
User Manual**

**UNITY PF
1K/1.5K/2K/3K
Rack/Tower Online UPS**

Uninterruptible Power Supply System

Version: 1.1

www.orionpowersystems.com

Table of Contents

1. Important Safety Warning	1
1-1. Transportation.....	1
1-2. Preparation	1
1-3. Installation.....	1
1-4. Operation.....	2
1-5. Maintenance, service and faults.....	3
2. Installation and setup	6
2-1. Rear panel view.....	6
2-2. Operating principle	7
2-3. Install the UPS	7
2-4. Setup the UPS.....	9
2-5. Battery Replacement	13
2-6 Battery Kit Assembly (option).....	15
3. Operations	18
3-1. Button operation	18
3-2. LCD Panel	18
3-3. Audible Alarm.....	20
3-4. LCD display wordings index.....	20
3-5. UPS Setting	20
3-6. Operating Mode Description	26
3-7. Faults Reference Code	27
3-8. Warning indicator	27
4. Troubleshooting	28
5. Storage and Maintenance.....	29
6. Specifications and Runtime Charts.....	30

1. Important Safety Warning - *Avertissement de sécurité important*

Please comply with all warnings and operating instructions in this manual strictly. Save this manual properly and read carefully the following instructions before installing the unit. Do not operate this unit before reading through all safety information and operating instructions carefully.

Veillez vous conformer strictement à tous les avertissements et instructions d'utilisation de ce manuel. Conservez ce manuel correctement et lisez attentivement les instructions suivantes avant d'installer l'unité. N'utilisez pas cet appareil avant d'avoir lu attentivement toutes les informations de sécurité et les instructions d'utilisation.

1-1. Transportation - Transport

- Please transport the UPS system only in the original package to protect against shock and impact. Veuillez transporter le système UPS uniquement dans son emballage d'origine pour le protéger des chocs et des potentiels contacts percutants.

1-2. Preparation - Préparation

- Condensation may occur if the UPS system is moved directly from cold to warm environment. The UPS system must be absolutely dry before being installed. Please allow at least two hours for the UPS system to acclimate the environment.
De la condensation peut se produire si le système UPS est directement déplacé d'un environnement froid à un environnement chaud. Le système UPS doit absolument être sec avant d'être installé. Veuillez prévoir au moins deux heures pour que le système UPS s'acclimate à l'environnement.
- Do not install the UPS system near water or in moist environments. . N'installez pas le système UPS près de l'eau ou dans des environnements humides.
- Do not install the UPS system where it would be exposed to direct sunlight or near heater. . N'installez pas le système UPS ni où il pourrait être exposé à la lumière directe du soleil ni à côté d'un chauffage.
- Do not block ventilation holes in the UPS housing. Ne bloquez pas les trous de ventilation dans le boîtier de l'onduleur.

1-3. Installation

- Do not connect appliances or devices which would overload the UPS system (e.g. laser printers) to the UPS output sockets. Ne connectez pas d'appareils ou de dispositifs susceptibles de surcharger le système UPS (par exemple, des imprimantes laser) aux prises de sortie UPS.
- Place cables in such a way that no one can step on or trip over them. Placez les câbles de manière à ce que personne ne puisse marcher dessus ou trébucher dessus.
- Do not connect domestic appliances such as hair dryers to UPS output sockets. Ne connectez pas d'appareils ménagers tels que des sèche-cheveux aux prises de sortie de l'onduleur.
- The UPS can be operated by any individuals with no previous experience. L'onduleur peut être utilisé par toute personne même sans expérience préalable.
- Connect the UPS system only to an earthed shockproof outlet which must be easily

accessible and close to the UPS system. Connectez le système UPS uniquement à une prise antichoc mise à la terre qui doit être facilement accessible et proche du système UPS.

- Please use only VDE-tested, CE-marked (or UL-marked for 100/110/115/120/127 VAC models) mains cable (e.g. the mains cable of your computer) to connect the UPS system to the building wiring outlet (shockproof outlet).
Veuillez utiliser uniquement un câble d'alimentation (par exemple le câble d'alimentation de votre ordinateur) homologué VDE, marqué CE (ou homologué UL pour les modèles 100/110/115/120/127 VAC) pour connecter le système UPS à la prise de câblage du bâtiment. (sortie antichoc).
- Please use only VDE-tested, CE-marked (or UL-marked for 100/110/115/120/127 VAC models) power cables to connect the loads to the UPS system. Veuillez utiliser uniquement des câbles d'alimentation testés VDE, marqués CE (ou UL pour les modèles 100/110/115/120/127 VAC) pour connecter les charges au système UPS.
- When installing the equipment, it should ensure that the sum of the leakage current of the UPS and the connected devices does not exceed 3.5mA. Lors de l'installation de l'équipement, il doit être assuré que la somme du courant de fuite de l'onduleur et des appareils connectés ne dépasse pas 3,5 mA.
- Temperature Rating - Units are considered acceptable for use in a maximum ambient of 40°C (104°F). Cote de température - Les unités sont considérées comme acceptables pour une utilisation dans une température ambiante maximale de 40 ° C (104 ° F).
- For PLUGGABLE EQUIPMENT, the socket-outlet shall be installed near the equipment and shall be easily accessible. Pour L'EQUIPEMENT ENFICHABLE, la prise de courant doit être installée près de l'équipement et doit être facilement accessible.

1-4. Operation - Opération

- Do not disconnect the mains cable on the UPS system or the building wiring outlet (shockproof socket outlet) during operations since this would cancel the protective earthing of the UPS system and of all connected loads. Ne débranchez pas le câble d'alimentation du système UPS ou de la prise de câblage du bâtiment (prise de courant antichoc) pendant les opérations car cela annulerait la protection par mise à la terre du système UPS et de toutes les charges connectées.
- The UPS system features its own, internal current source (batteries). The UPS output sockets or output terminals block may be electrically live even if the UPS system is not connected to the building wiring outlet. Le système UPS dispose de sa propre source de courant interne (batteries). Les prises de sortie de l'onduleur ou le bornier de sortie peuvent être sous tension, même si le système de l'onduleur n'est pas connecté à la prise de câblage du bâtiment.
- In order to fully disconnect the UPS system, first press the OFF/Enter button to disconnect the mains. Afin de complètement déconnecter le système UPS, appuyez d'abord sur le bouton OFF / Enter pour déconnecter le secteur.
- Prevent fluids or other foreign objects from getting inside of the UPS system. Empêchez tout liquide ou autre corps étranger de pénétrer à l'intérieur du système UPS.

1-5. Maintenance, service and faults - Maintenance, service et défauts

- The UPS system operates with hazardous voltages. Repairs may be carried out only by qualified maintenance personnel. Le système UPS fonctionne avec des tensions dangereuses. Les réparations ne peuvent être effectuées que par un personnel de maintenance qualifié.
- **Caution** - risk of electric shock. Even after the unit is disconnected from the mains (building wiring outlet), components inside the UPS system are still connected to the battery and electrically live and dangerous. **Attention** - risque de choc électrique. Même après que l'appareil soit déconnecté du secteur (prise de câblage du bâtiment), les composants à l'intérieur du système UPS sont toujours connectés à la batterie et sont sous tension électrique et dangereuse.
 - Before carrying out any kind of service and/or maintenance, disconnect the batteries and verify that no current is present and no hazardous voltage exists in the terminals of high capability capacitor such as BUS-capacitors. Avant d'effectuer tout type de service et / ou de maintenance, débranchez les batteries et vérifiez qu'aucun courant n'est présent et qu'aucune tension dangereuse ne soit présente aux bornes des condensateurs à haute capacité tels que les condensateurs BUS.
 - Only persons who are adequately familiar with batteries and with the required precautionary measures may replace batteries and supervise operations. Unauthorized persons must be kept well away from the batteries. Seules les personnes qui ont des connaissances suffisantes sur les batteries et les mesures de précaution requises peuvent remplacer les batteries et superviser les opérations. Les personnes non autorisées doivent être tenues à l'écart des batteries.
- **Caution** - risk of electric shock. The battery circuit is not isolated from the input voltage. Hazardous voltages may occur between the battery terminals and the ground. Before touching, please verify that no voltage is present! **Attention** - risque de choc électrique. Le circuit de la batterie n'est pas isolé de la tension d'entrée. Des tensions dangereuses peuvent se produire entre les bornes de la batterie et la terre. Avant de toucher, veuillez vérifier qu'aucune tension n'est présente!
 - **Caution** - Do not dispose of batteries in a fire. The batteries may explode. **Attention** - Ne jetez pas les piles au feu. Les piles peuvent exploser.
 - **Caution** - Do not open or mutilate batteries. Released electrolyte is harmful to the skin and eyes. It may be toxic. **Attention** - Ne pas ouvrir ou mutiler les batteries. L'électrolyte libéré est nocif pour la peau et les yeux. Il peut être toxique.
 - Batteries may cause electric shock and have a high short-circuit current. Please take the precautionary measures specified below and any other measures necessary when working with batteries:
 - a) Remove watches, rings, or other metal objects.
 - b) Use tools with insulated handles.
 - c) Wear rubber gloves and boots.
 - d) Do not lay tools or metal parts on top of batteries.
 - e) Disconnect charging source and load prior to installing or maintaining the battery.

- f) Remove battery grounds during installation and maintenance to reduce likelihood of shock. Remove the connection from ground if any part of the battery is determined to be grounded.

Les batteries peuvent provoquer un choc électrique et avoir un courant de court-circuit élevé. S'il vous plaît prendre les mesures de précaution spécifiées ci-dessous et toute autre mesure nécessaire lors du travail avec des piles:

- a) Retirez les montres, bagues ou autres objets métalliques.
- b) Utilisez des outils avec des poignées isolées.
- c) Portez des gants et des bottes en caoutchouc.
- d) Ne posez pas d'outils ou de pièces métalliques sur les piles.
- e) Déconnectez la source de charge et la charge avant d'installer ou d'entretenir la batterie.
- f) Enlever les sols de la batterie pendant l'installation et l'entretien pour réduire le risque de choc. Retirez la connexion de la terre si une partie de la batterie est déterminée comme étant mise à la terre

- When changing batteries, install the same number and same type of batteries or battery packs.

Lorsque vous changez les piles, installez le même nombre et le même type de piles ou Batteries.

Manufacture	Type	Rated
Toplite (Guangzhou) Technology Battery Co Ltd (MH29104)	NPW45-12	12 V dc, 9.0 Ah
	UXW460-12	12 V dc, 9.0 Ah
	NPW36-12	12 V dc, 7.2 Ah
	UXW360-12	12 V dc, 7.2 Ah
	NPW45-12 FR	12 V dc, 7.0 Ah
	UXW460-12/FR	12 V dc, 7.0 Ah
	NPW36-12 FR	12 V dc, 7.0 Ah
CSB Battery Co Ltd (MH14533)	UXW360-12/FR	12 V dc, 7.0 Ah
	GP1272	12 V dc, 7.2 Ah
	UPS 12460 F2	12 V dc, 9.0 Ah
	UPS 12360 6	12 V dc, 6.5 Ah
	UPS 12360 7	12 V dc, 6.5 Ah
	HR 1234W	12 V dc, 8.5 Ah
	HR 1234W FR	12 V dc, 8.5 Ah
Yuasa Battery (Guangdong) Co Ltd (MH29616)	NPW45-12	12 V dc, 8.0 Ah
	NPW45-12FR	12 V dc, 8.0 Ah

- For UPS with internally mounted battery Pour UPS avec batterie montée en interne
 - a) Instructions shall carry sufficient information to enable the replacement of the battery with a suitable manufacturer and catalogue number. Les instructions doivent contenir suffisamment d'informations pour permettre le remplacement de la batterie par un fabricant et un numéro de catalogue appropriés.
 - b) Safety instructions to allow access by Service Personnel shall be stated in the installation/service handbook. Les consignes de sécurité pour permettre l'accès par le personnel de service doivent être énoncées dans le manuel d'installation/d'entretien.
 - c) If batteries are to be installed by Service Personnel, instructions for interconnections, including terminal torque, shall be provided. Si des batteries doivent être installées par le personnel de service, des instructions pour les interconnexions, y compris le couple terminal, doivent être fournies.
- Do not attempt to dispose of batteries by burning them. This could cause battery explosion. N'essayez pas de vous débarrasser des piles en les brûlant. Cela pourrait causer de la batterie explosion.
- Do not open or destroy batteries. Escaping electrolyte can cause injury to the skin and eyes. It may be toxic. N'ouvrez ni ne détruisez les piles. L'échappement de l'électrolyte peut causer des blessures à la peau et aux yeux. Il peut être toxique.
- Please replace the fuse only with the same type and amperage in order to avoid fire hazards. Veuillez remplacer le fusible uniquement par le même type et le même ampérage afin d'éviter les risques d'incendie.
- Do not dismantle the UPS system. Ne démontez pas le système UPS.

2. Installation and setup - Installation et configuration

NOTE: Before installation, please inspect the unit. Be sure that nothing inside the package is damaged. Please keep the original package in a safe place for future use.

REMARQUE: Avant l'installation, veuillez inspecter l'appareil. Assurez-vous que rien à l'intérieur de l'emballage n'est endommagé. Veuillez conserver l'emballage d'origine dans un endroit sûr pour une utilisation future.

2-1. Rear panel view

IEC Type

1K/1.5K

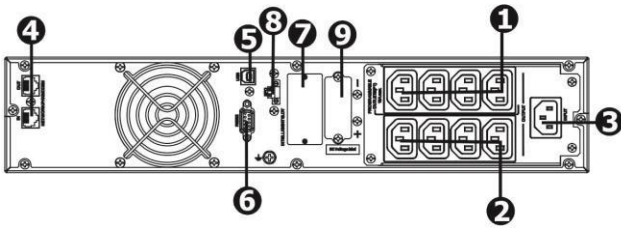

2K

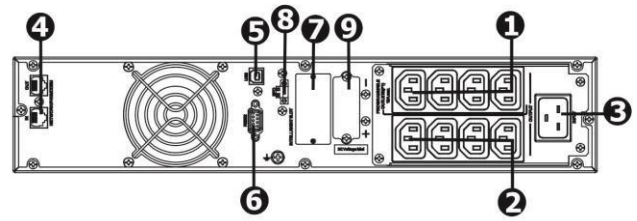

3K

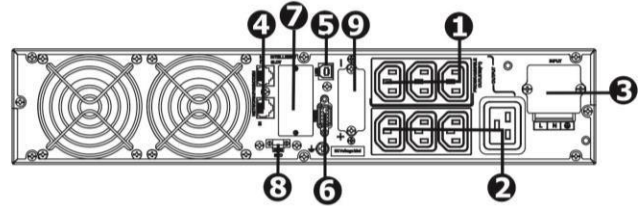
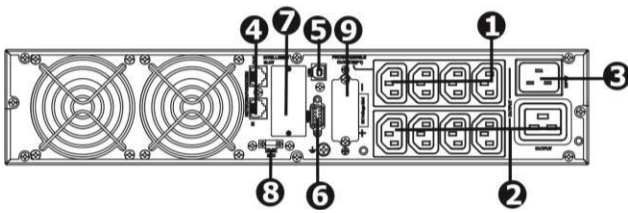

NEMA Type

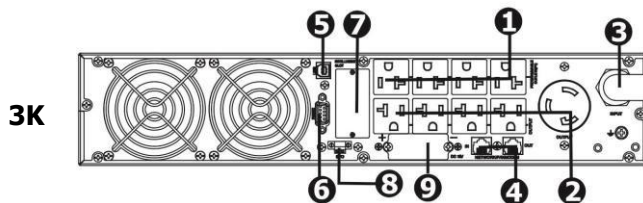
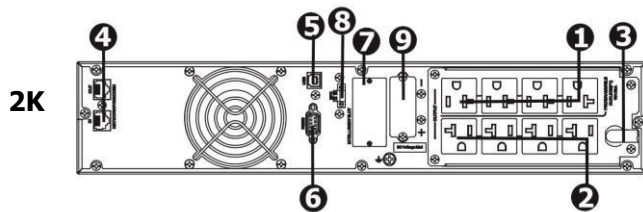
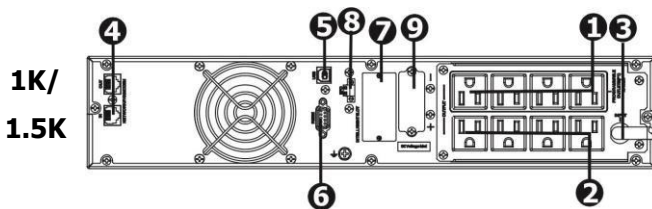

1. Programmable outlets: connect to non-critical loads.
2. Output receptacles: connect to mission-critical loads.
3. AC input
4. Network/Fax/Modem surge protection
5. USB communication port
6. RS-232 communication port
7. SNMP intelligent slot
8. Emergency power off port (EPO)
9. External battery connection

2-2. Operating principle

The operating principle of the UPS is shown as below

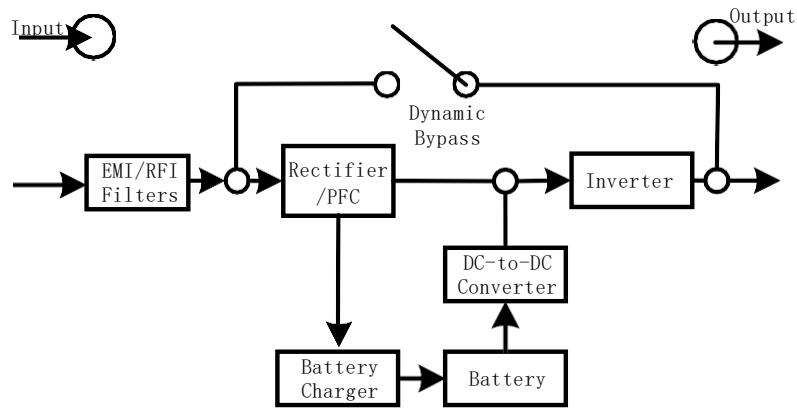

The UPS is composed of mains input, EMI/RFI filters, rectifier/PFC, inverter, battery charger, DC-to-DC converter, battery, dynamic bypass and UPS output.

2-3. Install the UPS

For safety consideration, the UPS is shipped out from factory without connecting battery wires. Before install the UPS, please follow below steps to re-connect battery wires first.

Step 1

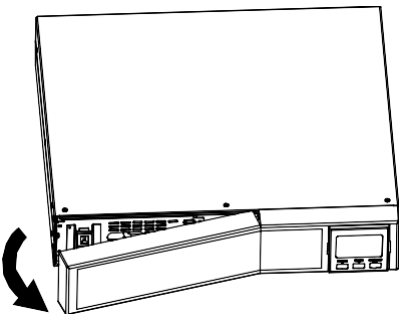

Remove front panel.

Step 2

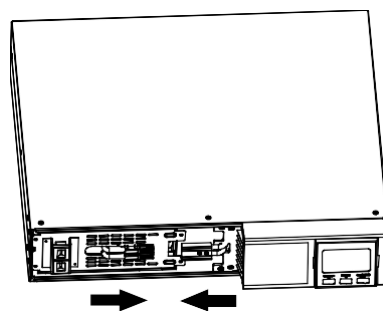

Connect the AC input, remove battery cover plate, and connect battery wires.

Step 3

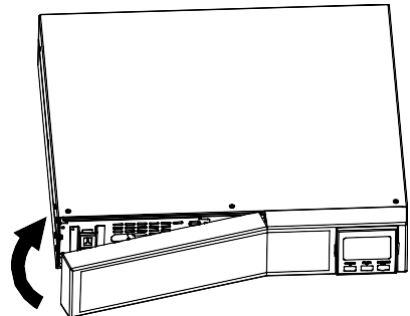

Re-install battery cover plate and put the front panel back to the unit.

This UPS can be either displayed on the desk or mounted in the 19" rack chassis. Please choose proper installation to position this UPS.

Rack-mount Installation

Step 1

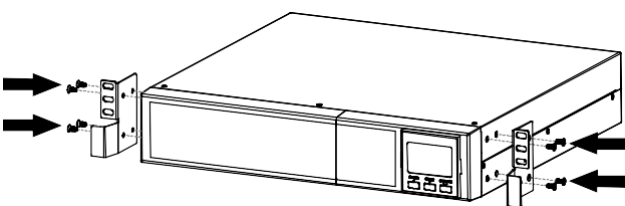

Step 2

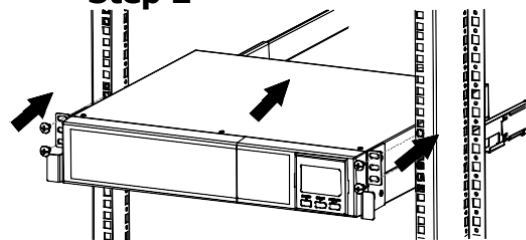

Tower Installation
Step 1

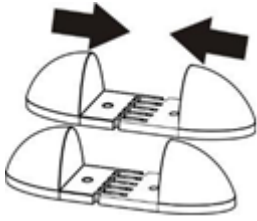

Step 2

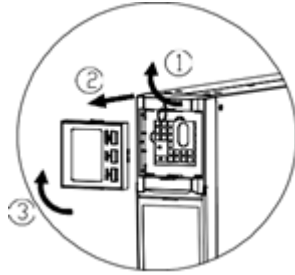

Step 3

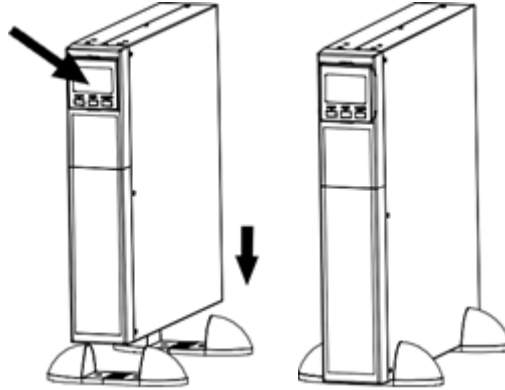

2-4. Setup the UPS - Configurer l'onduleur

Before installing the UPS, please read below to select proper location to install UPS. Avant d'installer l'onduleur, veuillez lire ci-dessous pour sélectionner l'emplacement approprié pour installer l'onduleur.

- UPS should be placed on the flat and clean surface. Place it in an area away from vibration, dust, humidity, high temperature, flammable liquids, gases, corrosive and conductive contaminants. Install the UPS indoors in a clean environment, where it is away from window and door. Maintain minimum clearance of 100mm in the bottom of the UPS to avoid dust and high temperature.

L'onduleur doit être placé sur la surface plane et propre. Placez-le dans un endroit éloigné des vibrations, de la poussière, de l'humidité, des températures élevées, des liquides inflammables, des gaz, des contaminants corrosifs et conducteurs. Installez l'onduleur à l'intérieur dans un environnement propre, où il est loin de la fenêtre et de la porte.

Maintenez un dégagement minimum de 100 mm dans le fond de l'onduleur pour éviter la poussière et les températures élevées.

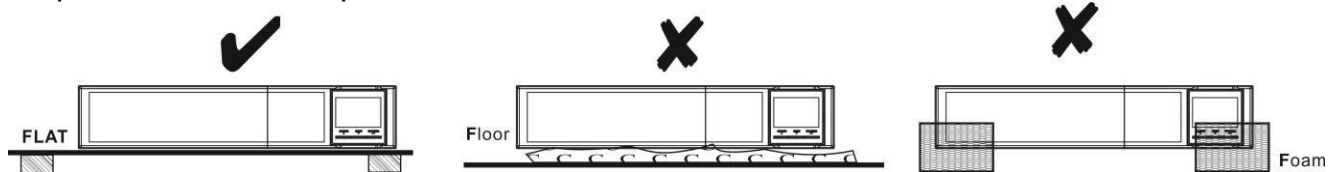

- Maintain an ambient temperature range of 0°C to 45°C for UPS optimal operation. For every 5°C above 45°C, the UPS will derate 12% of nominal capacity at full load. The highest working temperature requirement for UPS operation is 50°C. Maintenez une plage de température ambiante de 0 °C à 45 °C pour un fonctionnement optimal de l'onduleur. Pour chaque 5°C au-dessus de 45°C, l'onduleur dévaluera 12 % de la capacité nominale à pleine charge. La température de fonctionnement la plus élevée requise pour le fonctionnement de l'onduleur est de 50 ° C.
- It's required to maintain maximum altitude of 1000m to keep UPS normal operation at full load UPS. If it's used in high altitude area, please reduce connected load. Altitude derating power with connected loads for UPS normal operation is listed as below: Il est nécessaire de maintenir une altitude maximale de 1000 m pour maintenir le fonctionnement normal de l'onduleur à pleine charge. S'il est utilisé en haute altitude, veuillez réduire la charge connectée. La puissance de déclassement d'altitude avec des charges connectées pour le fonctionnement normal de l'onduleur est répertoriée ci-dessous:

Altitude m	Derating factor ¹⁾
1 000	1.0
1 500	0.95
2 000	0.91
2 500	0.86
3 000	0.82
3 500	0.78
4 000	0.74
4 500	0.7
5 000	0.67
NOTE - Note to table 1	
Based on density of dry air = 1.225 kg/m ³ at sea-level, +15 °C.	
¹⁾ Since fans lose efficiency with altitude, forced air-cooled equipment will have a smaller derating	

4. Place UPS - Placez UPS:

It's equipped with fan for cooling. Therefore, place the UPS in a well-ventilated area. It's required to maintain minimum clearance of 100mm in the front of the UPS and 300mm in the back and two sides of the UPS for heat dissipation and easy-maintenance.

Il est équipé d'un ventilateur pour le refroidissement. Par conséquent, placez l'onduleur dans un endroit bien ventilé. Il est nécessaire de maintenir un dégagement minimum de 100 mm à l'avant de l'onduleur et de 300 mm à l'arrière et sur les deux côtés de l'onduleur pour une dissipation de la chaleur et un entretien facile.

5. Connect to External Battery Pack - Se connecter à la batterie externe

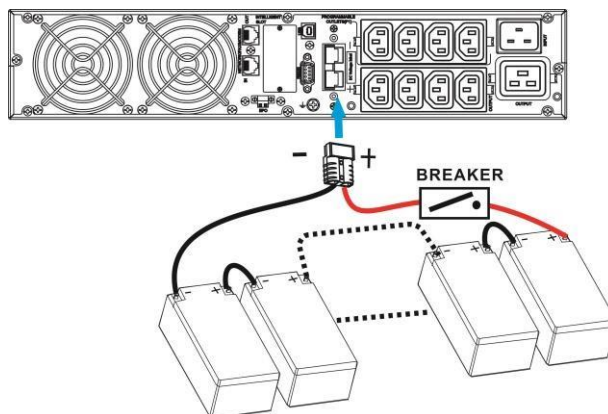

When connecting external battery packs, please be sure to connect polarity correctly. Connect positive pole of battery pack to positive pole of external battery connector in UPS and negative pole of battery pack to negative pole of external battery connector in UPS. Polarity misconnection will cause UPS internal fault. It's recommended to add one breaker between positive pole of battery pack and positive pole of external battery connector in UPS to prevent damage to battery packs from internal fault.

The required specification of breaker: voltage $\geq 1.25 \times$ battery voltage/set; current $\geq 50A$

Please choose battery size and connected numbers according to backup time requirement and UPS specifications. To extend battery lifecycle, it's recommended to use them in the temperature range of 15°C to 25°C.

Lorsque vous connectez des batteries externes, assurez-vous de connecter correctement la polarité. Connectez le pôle positif de la batterie au pôle positif du connecteur de la batterie externe dans l'onduleur et le pôle négatif de la batterie au pôle négatif du connecteur de la batterie externe dans l'onduleur. Une mauvaise connexion de polarité entraînera une défaillance interne de l'onduleur. Il est recommandé d'ajouter un disjoncteur entre le pôle positif de la batterie et le pôle positif du connecteur de batterie externe dans l'onduleur pour éviter d'endommager les batteries en cas de défaillance interne. La spécification requise du disjoncteur: tension $\geq 1,25 \times$ tension de batterie / ensemble; \geq actuelle 50A Veuillez choisir la taille de la batterie et les numéros connectés en fonction du temps de sauvegarde requis et des spécifications de l'onduleur. Pour prolonger le cycle de vie de la batterie, il est recommandé de les utiliser dans la plage de température de 15 ° C à 25 ° C.

Step 1: UPS input connection

Plug the UPS into a two-pole, three-wire, grounded receptacle only. Avoid using extension cords.

- For 200/208/220/230/240VAC models: The power cord is supplied in the UPS package.
- For 100/110/115/120/127VAC models: The power cord is attached to the UPS. The input plug is a NEMA 5-15P for 1K and 1.5K models, NEMA 5-20P for 2K model and NEMA L5-30P for 3K model.

Note: Check if the site wiring fault indicator lights up in LCD panel. It will be illuminated when the UPS is plugged into an improperly wired utility power outlet (Refer to Troubleshooting section). Please also check if there is a circuit breaker installed between the mains and AC input of the UPS against overcurrent and short circuit for safety operation. The recommended protection specification is listed as following:

- For 200/208/220/230/240VAC models: 10A for the 1K and 1.5K models, 16A for the 2K and 3K models.
- For 100/110/115/120/127VAC models: 15A for the 1K and 1.5K models, 20A for 2K model and 30A for 3K model.

Remarque : Vérifiez si l'indicateur de défaut de câblage du site s'allume sur l'écran LCD. Il s'allume lorsque l'onduleur est branché sur une prise de courant électrique mal câblée (reportez-vous à la section Dépannage). Veuillez également vérifier si un disjoncteur est installé entre le secteur et l'entrée CA de l'onduleur contre les surintensités et les courts-circuits pour un fonctionnement en toute sécurité. La spécification de protection recommandée est la suivante :

- Pour les modèles 200/208/220/230/240VAC: 10A pour les modèles 1K et 1.5K, 16A pour les modèles 2K et 3K.
- Pour les modèles 100/110/115/120/127VAC: 15A pour les modèles 1K et 1.5K, 20A pour le modèle 2K et 30A pour le modèle 3K

Step 3: UPS output connection

There two kinds of outputs: programmable outlets and general outlets. Please connect non-critical devices to the programmable outlets and critical devices to the general outlets. During power failure, you may extend the backup time to critical devices by setting shorter backup time for non-critical devices.

Step 4: Communication connection

Communication port:

USB port



RS-232 port

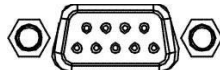

Intelligent slot



To allow for unattended UPS shutdown/start-up and status monitoring, connect the communication cable one end to the USB/RS-232 port and the other to the communication port of your PC. With the monitoring software installed, you can schedule UPS shutdown/start-up and monitor UPS status through PC.

The UPS is equipped with intelligent slot perfect for either SNMP or AS400 card. When installing either SNMP or AS400 card in the UPS, it will provide advanced communication and monitoring options.

Step 5: Network connection

Network/Fax/Phone surge port

IN   OUT

Connect a single modem/phone/fax line into surge-protected "IN" outlet on the back panel of the UPS unit. Connect from "OUT" outlet to the equipment with another modem/fax/phone line cable.

Step 6: Disable and enable EPO function

This UPS is equipped with EPO function. By default, the UPS is delivered from factory with Pin 1 and pin 2 closed (a metal plate is connected to Pin 1 and Pin2) for UPS normal operation. To activate EPO function, remove two screws on EPO port and metal plate will be removed.

Note: The EPO function logic can be set up via LCD setting. Please refer to program 16 in UPS setting for the details.

Remarque : La logique de la fonction EPO peut être configurée via le réglage DE L'écran LCD. Veuillez vous référer au programme 16 dans UPS pour les détails.

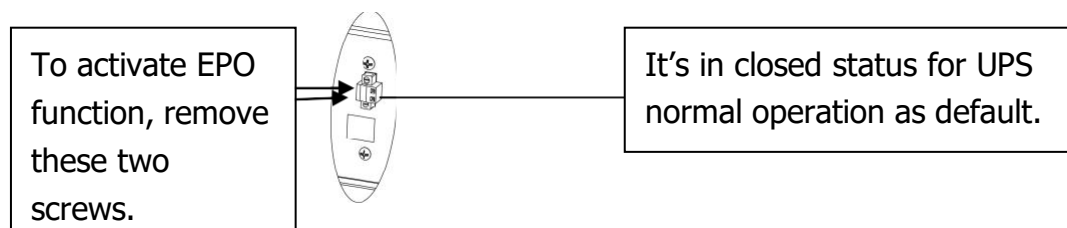

Step 7: Turn on the UPS

Press the ON/Mute button on the front panel for two seconds to power on the UPS.

Note: The battery charges fully during the first five hours of normal operation. Do not expect full battery run capability during this initial charge period.

Step 8: Install software

For optimal computer system protection, install UPS monitoring software to fully configure UPS shutdown. Use supplied RS-232 or USB communication cable to connect RS-232/USB port of UPS and RS-232/USB port of PC. Then, follow below steps to install monitoring software.

1. Insert the included installation CD into CD-ROM drive and then follow the on-screen instructions to proceed with software installation. If no screen shows 1 minute after inserting the CD, please execute setup.exe file for initiating software installation.
2. Follow the on-screen instructions to install the software.
3. When your computer restarts, the monitoring software will appear as an orange plug icon located in the system tray, near the clock.

2-5. Battery Replacement

NOTICE: This UPS is equipped with internal batteries and user can replace the batteries without shutting down the UPS or connected loads.(hot-swappable battery design)
Replacement is a safe procedure, isolated from electrical hazards.

CAUTION!! Consider all warnings, cautions, and notes before replacing batteries.

PRUDENCE!! Tenez compte de tous les avertissements, avertissements et notes avant de remplacer les piles.

Note: Upon battery disconnection, equipment is not protected from power outages.

Step 1

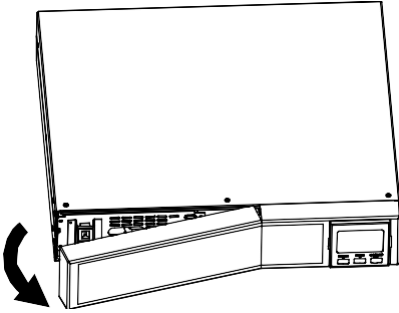

Remove front panel.

Step 2

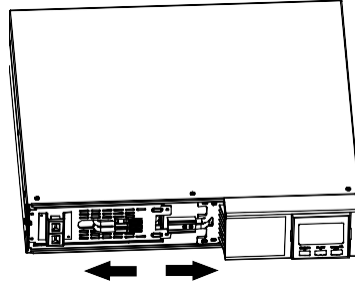

Remove battery cover plate and disconnect battery wires.

Step 3



Pull out the battery box.

Step 4

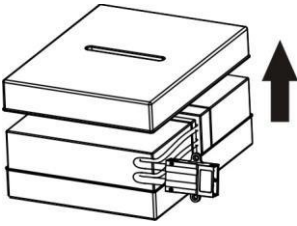

Remove the top cover of battery box and replace the inside batteries.

Step 5

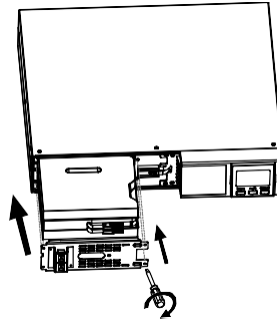

After replacing the batteries, put the battery box back to original location and re-connect the battery wires.

Step 6

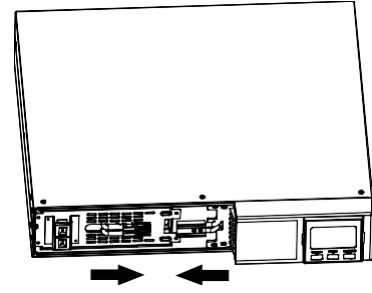

Install battery cover plate.

Step 7

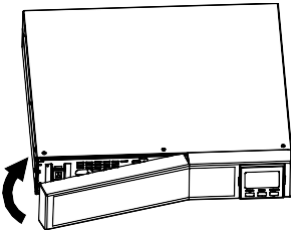

Put the front panel back on the unit.

2-6 Battery Kit Assembly (option)

NOTICE: Please assemble battery kit first before installing it inside of UPS. Please select correct battery kit procedure below to assemble it.

2- battery kit

Step 1: Remove adhesive tapes.

Tapes

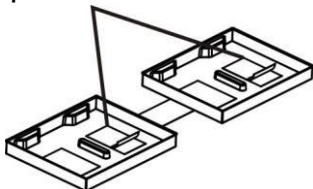

Step 3: Put assembled battery packs on one side of plastic shells.

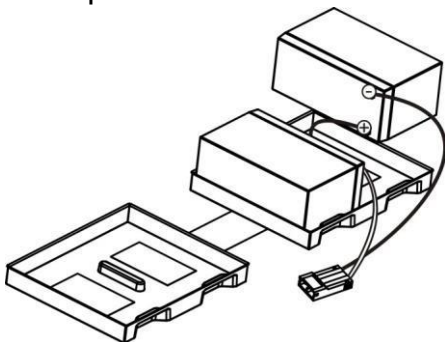

Step 2: Connect all battery terminals by following below drawing.

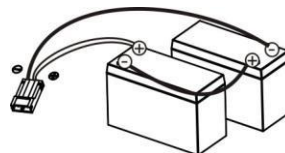

Step 4: Cover the other side with plastic shell as in below drawing.

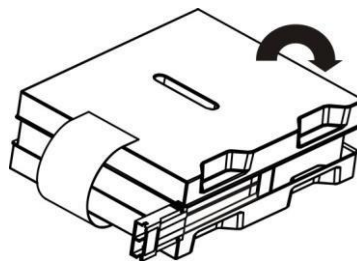

3-battery kit

Step 1: Remove adhesive tapes.

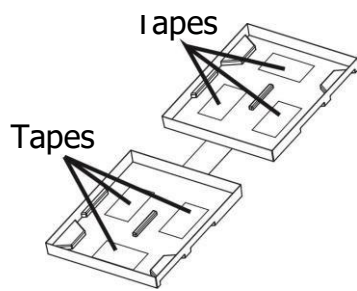

Step 2: Connect all battery terminals by following below drawing.

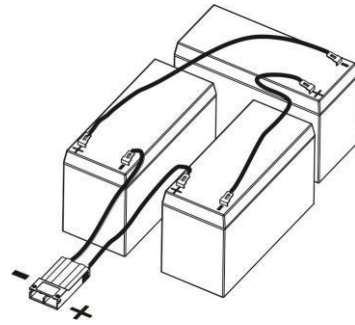

Step 3: Put assembled battery packs on one side of plastic shells as below drawing.

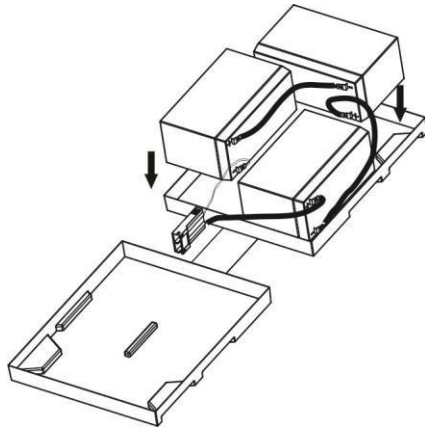

Step 4: Cover the other side of plastic shell as below drawing.

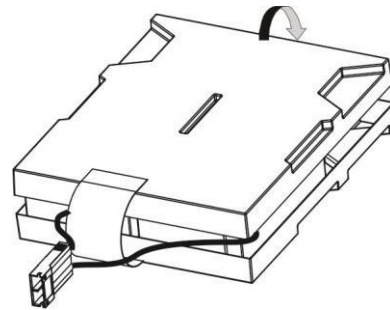

4-battery kit

Step 1: Remove adhesive tapes.

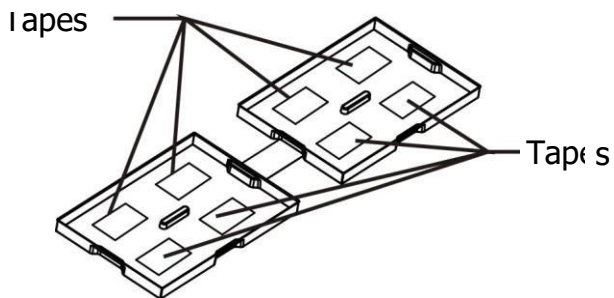

Step 2: Connect all battery terminals by following below drawing.

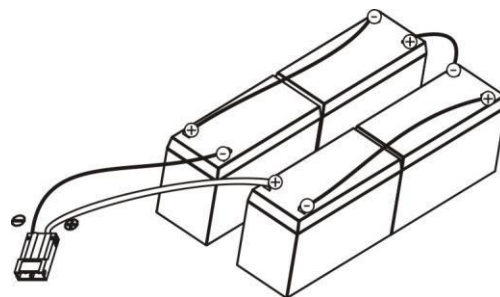

Step 3: Put assembled battery packs on one side of plastic shells.

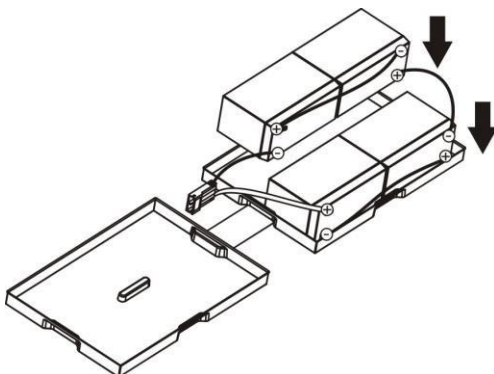

Step 4: Cover the other side of plastic shell as in below drawing.

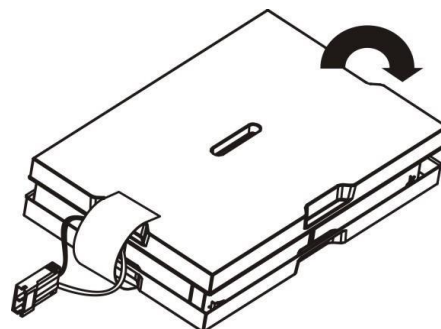

6-battery kit

Step 1: Remove adhesive tapes.

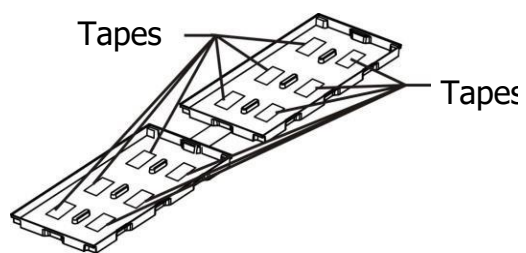

Step 2: Connect all battery terminals by following below drawing.

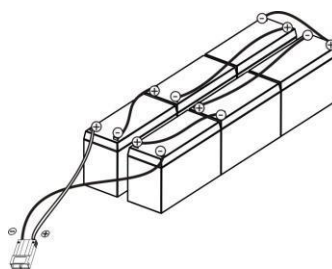

Step 3: Put assembled battery packs on one side of plastic shells.

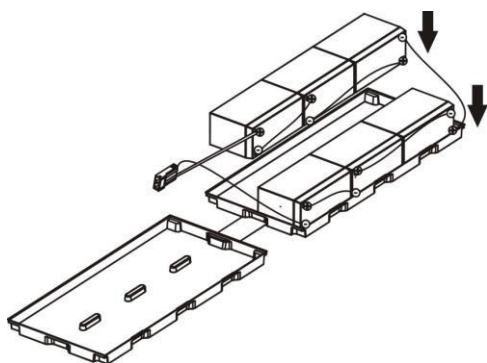

Step 4: Cover the other side of plastic shell as in below drawing.

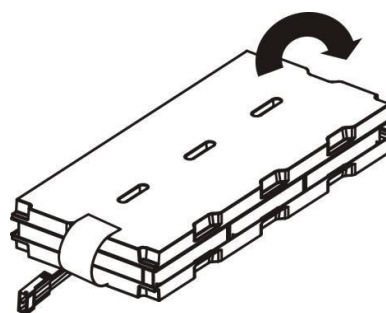









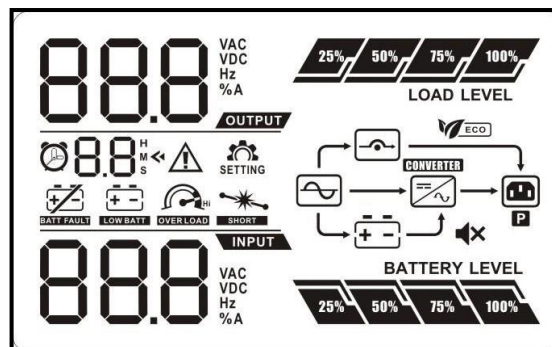







3. Operations

3-1. Button operation

Button	Function
ON/Mute Button	<ul style="list-style-type: none"> ➤ Turn on the UPS: Press and hold ON/Mute button for at least 2 seconds to turn on the UPS. ➤ Mute the alarm: After the UPS is turned on in battery mode, press and hold this button for at least 3 seconds to disable or enable the alarm system. Does not apply to situations when warnings or errors occur. ➤ Up key: Press this button to display previous selection in UPS setting mode. ➤ Switch to UPS self-test mode: Press ON/Mute buttons for 3 seconds to enter UPS self-testing while in AC mode, ECO mode, or converter mode.
OFF/Enter Button	<ul style="list-style-type: none"> ➤ Turn off the UPS: Press and hold this button at least 2 seconds to turn off the UPS. UPS will be in standby mode under power normal or transfer to Bypass mode if the Bypass enable setting by pressing this button. ➤ Confirm selection key: Press this button to confirm selection in UPS setting mode.
Select Button	<ul style="list-style-type: none"> ➤ Switch LCD message: Press this button to change the LCD message for input voltage, input frequency, battery voltage, output voltage, and output frequency. ➤ Setting mode: Press and hold this button for 3 seconds to enter UPS setting mode when in Standby and Bypass mode. ➤ Down key: Press this button to display next selection in UPS setting mode.
ON/Mute + Select Button	<ul style="list-style-type: none"> ➤ Switch to bypass mode: When the main power is normal, press ON/Mute and Select buttons simultaneously for 3 seconds. Then UPS will enter to bypass mode. This action will be ineffective when the input voltage is out of acceptable range. ➤ Exit setting mode or return to the upper menu: When working in setting mode, press ON/Mute and Select buttons simultaneously for 0.2 seconds to return to the upper menu. If it's already in top menu, press these two buttons at the same time to exit the setting mode.

3-2. LCD Panel

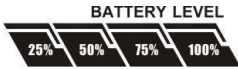

Display	Function
Backup time information	
 8.8 ^H _M _S	Indicates the estimated backup time. H: hours, M: minute, S: second.
Configuration and fault information	
8.8 <	Indicates the configuration items, and the configuration items are listed in details in section 3-5.
8.8 < 	Indicates the warning and fault codes, and the codes are listed in details in section 3-7 and 3-8.
Mute operation	
	Indicates that the UPS alarm is disabled.
Output information	
88.8 ^{VAC} ^{VDC} ^{Hz} ^{%A} OUTPUT	Indicates the output voltage and output frequency. Vac: AC voltage, Vdc: DC voltage, Hz: frequency
Load information	
 LOAD LEVEL	Indicates the load level by 0-24%, 25-49%, 50-74% and 75-100%.
 OVER LOAD	Indicates overload.
 SHORT	Indicates the load or the UPS output is short circuit.
Programmable outlets information	
	Indicates that programmable management outlets are working.
Mode operation information	
	Indicates the UPS connects to the mains.
	Indicates the battery is working.
	Indicates the bypass circuit is working.
	Indicates the ECO mode is enabled.
	Indicates the inverter circuit is working.
	Indicates the output is working.
Battery information	
 BATTERY LEVEL	Indicates the battery level by 0-24%, 25-49%, 50-74%, and 75-100%.
 BATT FAULT	Indicates the battery is fault.
 LOW BATT	Indicates low battery.
Input & battery information	
88.8 ^{VAC} ^{VDC} ^{Hz} ^{%A} INPUT	Indicate the input voltage, input frequency and battery voltage. Vac: AC voltage, Vdc: DC voltage, Hz: frequency

3-3. Audible Alarm

Battery Mode	Sounding every 5 seconds
Low Battery	Sounding every 2 seconds
Overload	Sounding every second
Fault	Continuously sounding
Bypass Mode	Sounding every 10 seconds

3-4. LCD display wordings index

Abbreviation	Display content	Meaning
ENA	ENA	Enable
DIS	DIS	Disable
ESC	ESC	Escape
HLS	HLS	High loss
LLS	LLS	Low loss
AO	AO	Active open
AC	AC	Active close
EAT	EAT	Estimated autonomy time
RAT	RAT	Running autonomy time
OK	OK	OK
ON	ON	ON
OI	OI	Over input current
SF	SF	Site wiring fault
EP	EP	EPO
TP	TP	Temperature
CH	CH	Charger
FU	FU	Bypass frequency unstable
BR	BR	Battery Replace
EE	EE	EEPROM error

3-5. UPS Setting

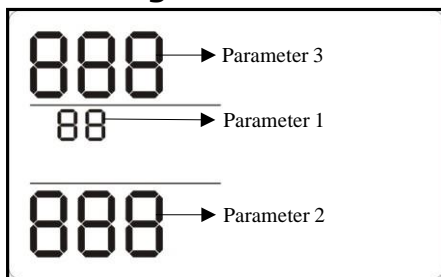

There are three parameters to set up the UPS. Parameter 1: It's for program alternatives. Refer to below table. Parameter 2 and parameter 3 are the setting options or values for each program.

● **01: Output voltage setting**

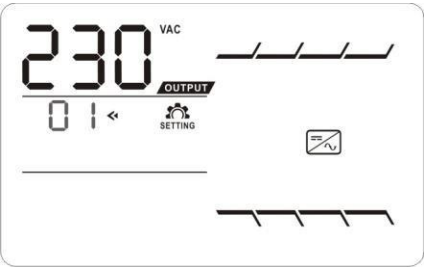
Interface	Setting
	<p>Parameter 2: Output voltage For 200/208/220/230/240 VAC models, you may choose the following output voltage: 200: presents output voltage is 200Vac 208: presents output voltage is 208Vac 220: presents output voltage is 220Vac 230: presents output voltage is 230Vac (Default) 240: presents output voltage is 240Vac For 100/110/115/120/127 VAC models, you may choose the following output voltage: 100: presents output voltage is 100Vac 110: presents output voltage is 110Vac 115: presents output voltage is 115Vac 120: presents output voltage is 120Vac (Default) 127: presents output voltage is 127Vac</p>

● **02: Frequency Converter enable/disable**

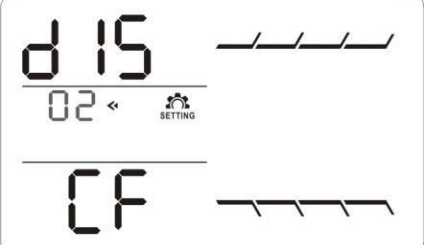
Interface	Setting
	<p>Parameter 2: Enable or disable converter mode. You may choose the following two options: CF ENA: converter mode enable CF DIS: converter mode disable (Default)</p>

● **03: Output frequency setting**

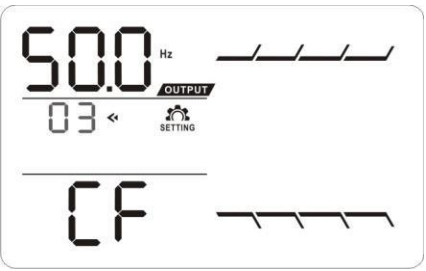
Interface	Setting
	<p>Parameter 2: Output frequency setting. You may set the initial frequency on battery mode: BAT 50: presents output frequency is 50Hz BAT 60: presents output frequency is 60Hz If converter mode is enabled, you may choose the following output frequency: CF 50: presents output frequency is 50Hz CF 60: presents output frequency is 60Hz</p>

● **04: ECO enable/disable**

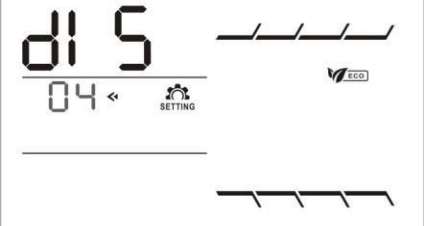
Interface	Setting
	<p>Parameter 2: Enable or disable ECO function. You may choose the following two options: ENA: ECO mode enable DIS: ECO mode disable (Default)</p>

● **05: ECO voltage range setting**

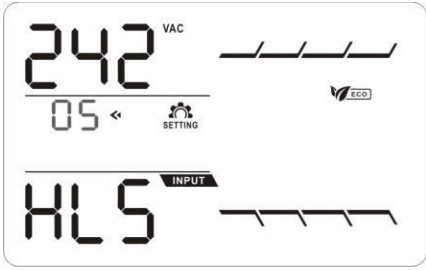
Interface	Setting
 <p>The LCD display shows '242 VAC' at the top, '05 <' below it, and 'HLS INPUT' at the bottom. There are also icons for 'SETTING' and 'ECO'.</p>	<p>Parameter 2: Set the acceptable high voltage point and low voltage point for ECO mode by pressing Down key or Up key.</p> <p>HLS: High loss voltage in ECO mode in parameter 2. For 200/208/220/230/240 VAC models, the setting range in parameter 3 is from +7V to +24V of the nominal voltage. (Default: +12V) For 100/110/115/120/127 VAC models, the setting range in parameter 3 is from +3V to +12V of the nominal voltage. (Default: +6V)</p> <p>LLS: Low loss voltage in ECO mode in parameter 2. For 200/208/220/230/240 VAC models, the setting range in parameter 3 is from -7V to -24V of the nominal voltage. (Default: -12V) For 100/110/115/120/127 VAC models, the setting voltage in parameter 3 is from -3V to -12V of the nominal voltage. (Default: -6V)</p>

● **06: Bypass enable/disable when UPS is off**

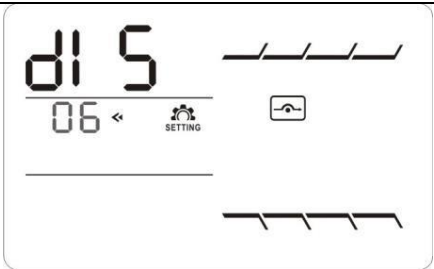
Interface	Setting
 <p>The LCD display shows 'dl 5' at the top, '06 <' below it, and a bypass icon. There are also icons for 'SETTING' and 'ECO'.</p>	<p>Parameter 2: Enable or disable Bypass function. You may choose the following two options:</p> <p>ENA: Bypass enable</p> <p>DIS: Bypass disable (Default)</p>

● **07: Bypass voltage range setting**

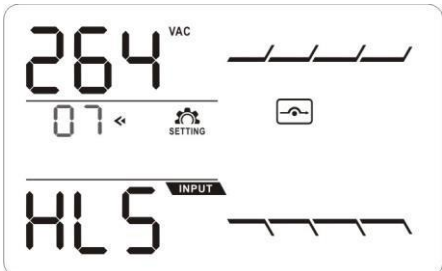
Interface	Setting
 <p>The LCD display shows '264 VAC' at the top, '07 <' below it, and 'HLS INPUT' at the bottom. There are also icons for 'SETTING' and 'ECO'.</p>	<p>Parameter 2: Set the acceptable high voltage point and acceptable low voltage point for Bypass mode by pressing the Down key or Up key.</p> <p>HLS: Bypass high voltage point For 200/208/220/230/240 VAC models: 230-264: setting the high voltage point in parameter 3 from 230Vac to 264Vac. (Default: 264Vac) For 100/110/115/120/127 VAC models: 120-140: setting the high voltage point in parameter 3 from 120Vac to 140Vac. (Default: 132Vac)</p> <p>LLS: Bypass low voltage point For 200/208/220/230/240 VAC models: 170-220: setting the low voltage point in parameter 3 from 170Vac to 220Vac. (Default: 170Vac) For 100/110/115/120/127 VAC models: 85-115: setting the low voltage point in parameter 3 from 85Vac to 115Vac. (Default: 85Vac)</p>

● **08: Bypass frequency range setting**

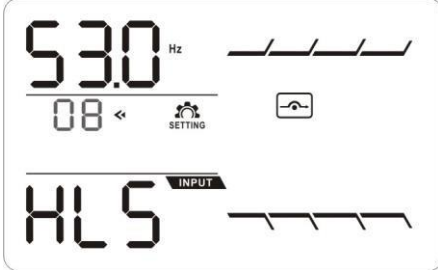
Interface	Setting
	<p>Parameter 2: Set the acceptable high frequency point and acceptable low frequency point for Bypass mode by pressing the Down key or Up key.</p> <p>HLS: Bypass high frequency point For 50Hz output frequency models: 51-55Hz: setting the frequency high loss point from 51Hz to 55Hz(Default: 53.0Hz) For 60Hz output frequency models: 61-65Hz: setting the frequency high loss point from 61Hz to 65Hz(Default: 63.0Hz)</p> <p>LLS: Bypass low Frequency point For 50Hz output frequency models: 45-49Hz: setting the frequency low loss point from 45Hz to 49Hz(Default: 47.0Hz) For 60Hz output frequency models: 55-59Hz: setting the frequency low loss point from 55Hz to 59Hz(Default: 57.0Hz)</p>

● **09: Programmable outlets enable/disable**

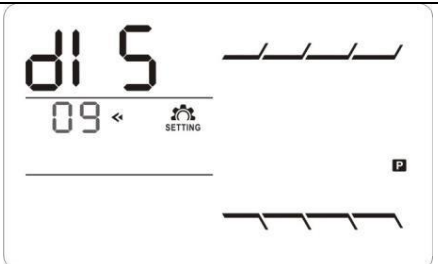
Interface	Setting
	<p>Parameter 2: Enable or disable programmable outlets.</p> <p>ENA: Programmable outlets enable DIS: Programmable outlets disable (Default)</p>

● **10: Programmable outlets setting**

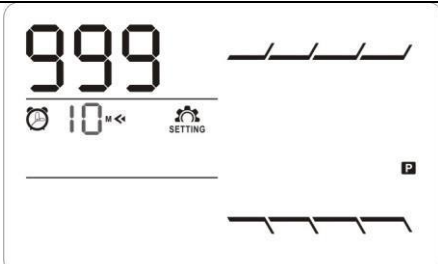
Interface	Setting
	<p>Parameter 2: Set up backup time limits for programmable outlets.</p> <p>0-999: setting the backup time limits in minutes from 0-999 for programmable outlets which connect to non-critical devices on battery mode. (Default: 999)</p>

● **11: Autonomy limitation setting**

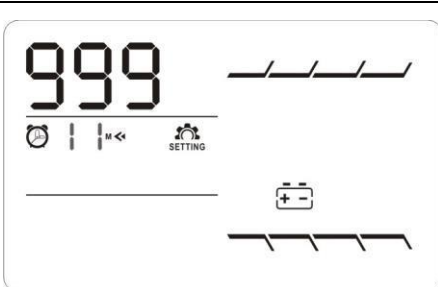
Interface	Setting
	<p>Parameter 2: Set up backup time on battery mode for general outlets.</p> <p>0-999: setting the backup time in minutes from 0-999 for general outlets on battery mode.</p> <p>DIS: Disable the autonomy limitation and the backup time will depend on battery capacity. (Default)</p> <p>Note: When setting as "0", the backup time will be only 10 seconds.</p>

● **12: Battery total AH setting**

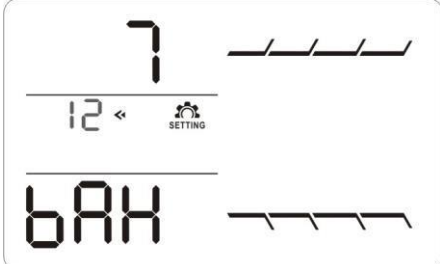
Interface	Setting
	<p>Parameter 2: Set up the battery total AH of the UPS. 7-999: setting the battery total capacity from 7-999 in AH. Please set the correct battery total capacity if external battery bank is connected.</p>

● **13: Maximum charger current setting**

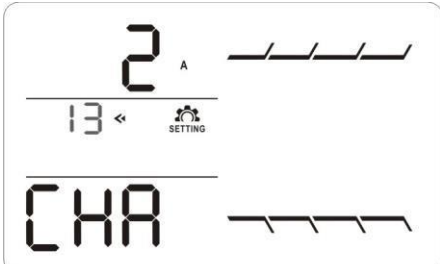
Interface	Setting														
	<p>Parameter 2: Set up the charger maximum current. For low voltage model with 24/36/48VDC 1/2/4/6/8: setting the charger maximum current 1/2/4/6/8 in Ampere. (Default: 2A) For high voltage model with 24/36/48VDC 1/2/4/6/8/10/12: setting the charger maximum current 1/2/4/6/8/10/12 in Ampere. (Default: 2A) For low voltage and high voltage model with 72/96VDC 1/2/4/6/8: setting the charger maximum current 1/2/4/6/8 in Ampere. (Default: 2A) Note: Please set the appropriate charger current based on battery capacity used. The recommended charging current is 0.1C~0.3C of battery capacity as following table for reference.</p> <table border="1" data-bbox="630 1108 1337 1350"> <thead> <tr> <th>Battery capacity(AH)</th> <th>Total charging current (A)</th> </tr> </thead> <tbody> <tr> <td>7~20</td> <td>2</td> </tr> <tr> <td>20~40</td> <td>4</td> </tr> <tr> <td>40~60</td> <td>6</td> </tr> <tr> <td>60~80</td> <td>8</td> </tr> <tr> <td>80~100</td> <td>10</td> </tr> <tr> <td>100~150</td> <td>12</td> </tr> </tbody> </table>	Battery capacity(AH)	Total charging current (A)	7~20	2	20~40	4	40~60	6	60~80	8	80~100	10	100~150	12
Battery capacity(AH)	Total charging current (A)														
7~20	2														
20~40	4														
40~60	6														
60~80	8														
80~100	10														
100~150	12														

● **14: Charger boost voltage setting**

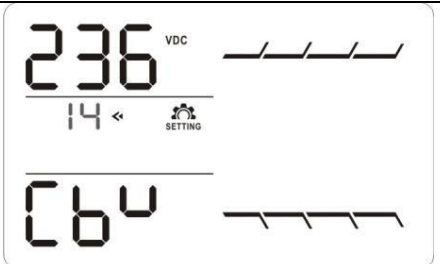
Interface	Setting
	<p>Parameter 2: Set up the charger boost voltage. 2.25-2.40: setting the charger boost voltage from 2.25 V/cell to 2.40V/cell. (Default: 2.36V/cell)</p>

● **15: Charger float voltage setting**

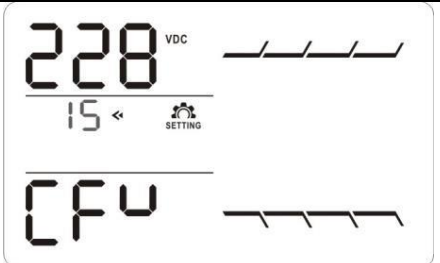
Interface	Setting
	<p>Parameter 2: Set up the charger float voltage. 2.20-2.33: setting the charger float voltage from 2.20 V/cell to 2.33V/cell. (Default: 2.28V/cell)</p>

● **16: EPO logic setting**

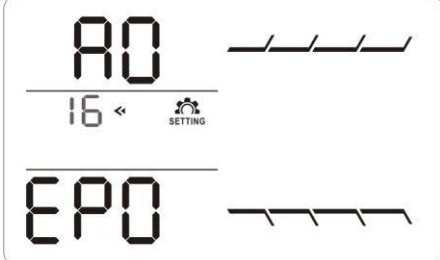
Interface	Setting
	<p>Parameter 2: Set up the EPO function control logic.</p> <p>AO: Active Open (Default). When AO is selected as EPO logic, it will activate EPO function with Pin 1 and Pin 2 in open status.</p> <p>AC: Active Close. When AC is selected as EPO logic, it will activate EPO function with Pin 1 and Pin 2 in close status.</p>

● **17: External output isolation transformer connection**

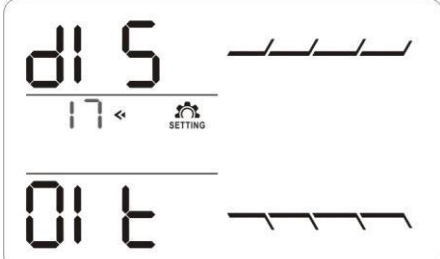
Interface	Setting
	<p>Parameter 2: Allow or disallow external output isolation transformer connection.</p> <p>ENA: If selected, it's allowed to connect to an external output isolation transformer.</p> <p>DIS: If selected, it's not allowed to connect to external output isolation transformer. (Default)</p>

● **18: Display setting for autonomy time**

Interface	Setting
	<p>Parameter 2: Set up the display setting for autonomy time</p> <p>EAT: If EAT is selected, it will display the remaining autonomy time. (Default)</p> <p>RAT: If RAT is selected, it will show accumulated autonomy time so far.</p>

● **19: Acceptable input voltage range setting**

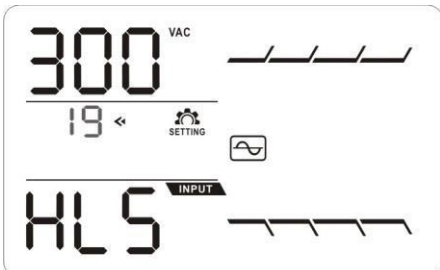
Interface	Setting
	<p>Parameter 2: Set the acceptable high voltage point and acceptable low voltage point for input voltage range by pressing the Down key or Up key.</p> <p>HLS: Input high voltage point</p> <p>For 200/208/220/230/240 VAC models: 280/290/300: setting the high voltage point in parameter 2. (Default: 300Vac)</p> <p>For 100/110/115/120/127 VAC models: 140/145/150: setting the high voltage point in parameter 2. (Default: 150Vac)</p> <p>LLS: Bypass low voltage point</p> <p>For 200/208/220/230/240 VAC models: 110/120/130/140/150/160: setting the low voltage point in parameter 2. (Default: 110Vac)</p> <p>For 100/110/115/120/127 VAC models: 55/60/65/70/75/80: setting the low voltage point in parameter 2. (Default: 55Vac)</p>



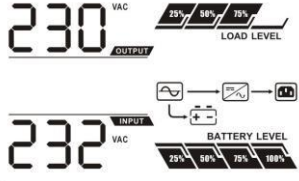
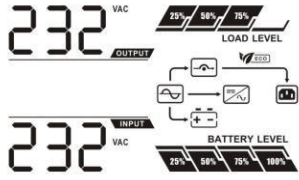
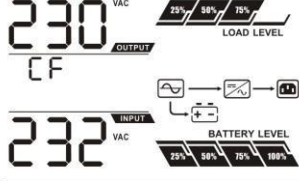
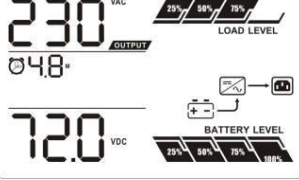
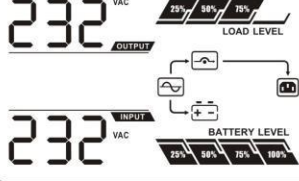
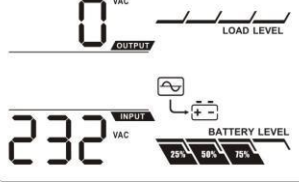
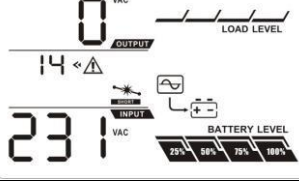

● 00: Exit setting

Interface	Setting
	Exit the setting mode.





















3-6. Operating Mode Description

Operating mode	Description	LCD display
Online mode	When the input voltage is within acceptable range, UPS will provide pure and stable AC power to output. The UPS will also charge the battery at online mode.	
ECO mode	Energy saving mode: When the input voltage is within voltage regulation range, UPS will bypass voltage to output for energy saving. The UPS will also charge the battery at ECO mode.	
Frequency Converter mode	When input frequency is within 40 Hz to 70 Hz, the UPS can be set at a constant output frequency, 50 Hz or 60 Hz. The UPS will still charge battery under this mode.	
Battery mode	When the input voltage is beyond the acceptable range or power failure, the UPS will backup power from battery and alarm is sounding every 5 seconds.	
Bypass mode	When input voltage is within acceptable range but UPS is overload, UPS will enter bypass mode or bypass mode can be set by front panel. Alarm is sounding every 10 seconds.	
Standby mode	UPS is powered off and no output supply power, but still can charge batteries.	
Fault mode	When a fault has occurred, the ERROR icon and the fault code will be displayed.	

3-7. Faults Reference Code

Fault event	Fault code	Icon	Fault event	Fault code	Icon
Bus start fail	01	x	Battery voltage too high	27	
Bus over	02	x	Battery voltage too low	28	
Bus under	03	x	Charger output short	2A	x
Inverter soft start fail	11	x	Over temperature	41	x
Inverter voltage high	12	x	Overload	43	
Inverter voltage Low	13	x	Charger failure	45	x
Inverter output short	14		Over input current	49	x











3-8. Warning indicator

Warning	Icon (flashing)	Code	Alarm
Low Battery	 		Sounding every 2 seconds
Overload	 		Sounding every second
Over input current		OI	Sounding 2 beep every 10 seconds
Battery is not connected	 		Sounding every 2 seconds
Over Charge	 		Sounding every 2 seconds
Site wiring fault	 	SF	Sounding every 2 seconds
EPO enable		EP	Sounding every 2 seconds
Over temperature		EP	Sounding every 2 seconds
Charger failure		CH	Sounding every 2 seconds
Battery fault	 		Sounding every 2 seconds (At this time, UPS is off to remind users something wrong with battery)
Out of bypass voltage range	 		Sounding every 2 seconds
Bypass frequency unstable		FU	Sounding every 2 seconds
Battery replacement		BT	Sounding every 2 seconds
EEPROM error		EE	Sounding every 2 seconds

NOTE: "Site Wiring Fault" function can be enabled/disabled via software. Please check software manual for the details.

4. Troubleshooting

If the UPS system does not operate correctly, please solve the problem by using the table below.

Symptom	Possible cause	Remedy
No indication and alarm even though the mains is normal.	The AC input power is not connected well.	Check if input power cord firmly connected to the mains.
	The AC input is connected to the UPS output.	Plug AC input power cord to AC input correctly.
The icon  and the warning code  flash on LCD display. Alarm is sounding every 2 seconds.	EPO function is activated.	Set the circuit in closed position to disable EPO function.
The icons of  and  flash on LCD display and alarm is sounding every 2 seconds.	Line and neutral conductors of UPS input are reversed.	Rotate mains power socket by 180° and then connect to UPS system.
The icons of  and  flashes on LCD display and alarm is sounding every 2 seconds.	The external or internal battery is incorrectly connected.	Check if all batteries are connected well.
Fault code is shown as 27 and the icon  is lighting on LCD display. Alarm is continuously sounding.	Battery voltage is too high or the charger is fault.	Contact your dealer.
Fault code is shown as 28 and the icon  is lighting on LCD display. Alarm is continuously sounding.	Battery voltage is too low or the charger is fault.	Contact your dealer.
The icons of  and  flash on LCD display and alarm is sounding every second.	UPS is overload	Remove excess loads from UPS output.
	UPS is overloaded. Devices connected to the UPS are fed directly by the electrical network via the Bypass.	Remove excess loads from UPS output.
	After repetitive overloads, the UPS is locked in the Bypass mode. Connected devices are fed directly by the mains.	Remove excess loads from UPS output first. Then shut down the UPS and restart it.
Fault code is shown as 49 on LCD display and alarm is continuously sounding.	UPS is over input current.	Remove excess loads from UPS output.
Fault code is shown as 43 and the icon  is lighting on LCD display. Alarm is continuously sounding.	The UPS shut down automatically because of overload at the UPS output.	Remove excess loads from UPS output and restart it.

Symptom	Possible cause	Remedy
Fault code is shown as 14 and the icon  is lighting on LCD display. Alarm is continuously sounding.	The UPS shut down automatically because short circuit occurs on the UPS output.	Check output wiring and if connected devices are in short circuit status.
Fault code is shown as 01, 02, 03, 11, 12, 13 and 41 on LCD display and alarm is continuously sounding.	A UPS internal fault has occurred. There are two possible results: 1. The load is still supplied, but directly from AC power via bypass. 2. The load is no longer supplied by power.	Contact your dealer
Battery backup time is shorter than nominal value.	Batteries are not fully charged	Charge the batteries for at least 5 hours and then check capacity. If the problem still persists, consult your dealer.
	Batteries defect	Contact your dealer to replace the battery.
Fault code is shown as 2A on LCD display and alarm is continuously sounding.	The short circuit occurs on the charger output.	Check if battery wiring of connected external pack is in short circuit status.
Fault code is shown as 45 on LCD display. At the same time, alarm is continuously sounding.	The charger does not have output and battery voltage is less than 10V/PC.	Contact your dealer.

5. Storage and Maintenance

Operation

The UPS system contains no user-serviceable parts. If the battery service life (3~5 years at 25°C ambient temperature) has been exceeded, the batteries must be replaced. In this case, please contact your dealer.



Be sure to deliver the spent battery to a recycling facility or ship it to your dealer in the replacement battery packing material.

Storage

Before storing, charge the UPS 5 hours. Store the UPS covered and upright in a cool, dry location. During storage, recharge the battery in accordance with the following table:

Storage Temperature	Recharge Frequency	Charging Duration
-25°C - 40°C	Every 3 months	1-2 hours
40°C - 45°C	Every 2 months	1-2 hours

6. Specifications

* Derate capacity to 80% of capacity when the output voltage is adjusted to 100VAC, 200VAC or 208VAC.

** Product specifications are subject to change without further notice.

MODEL		DC1000RTX1	DC1500RTX1	DC2000RTX1	DC3000RTX1	DC3000RTX1HV
CAPACITY*		1000VA/1000W	1500VA/1500W	2000VA/2000W	3000VA / 3000W	3000VA / 3000W
INPUT						
Voltage Range	Low Line Transfer	160VAC/140VAC/120VAC/110VAC ± 5 % or 80VAC/70VAC/60VAC/55VAC ± 5 % (based on load percentage 100% - 80 % / 80 % - 70 % / 70 - 60 % / 60 % - 0)				
	Low Line Come back	175VAC/155VAC/135VAC/125VAC ± 5 % or 87VAC/77VAC/67VAC/62VAC ± 5 %				
	High Line Transfer	300 VAC ± 5 % or 150 VAC ± 5 %				
	High Line Come back	290 VAC ± 5 % or 145 VAC ± 5 %				
Frequency Range		40Hz ~ 70 Hz				
Phase		Single phase with ground				
Power Factor		≥ 0.99 @ full load				
THDi		≤ 5% @ 205-245VAC or 100~130VAC THDU < 1.6% @ input and full linear load condition				
OUTPUT						
Output voltage		200/208/220/230/240VAC or 100/110/115/120/127 VAC				
AC Voltage Regulation		± 1% (Batt. Mode)				
Frequency Range (Synchronized Range)		47 ~ 53 Hz or 57 ~ 63 Hz				
Frequency Range		50 Hz ± 0.1 Hz or 60Hz ± 0.1 Hz (Batt. Mode)				
Current Crest Ratio		3:1				
Harmonic Distortion		≤ 2 % THD (Linear Load) ; 4 % THD (Non-linear Load)				
Transfer Time	AC Mode to Batt. Mode	Zero				
	Inverter to Bypass	< 4 ms				
Waveform (Batt. Mode)		Pure Sinewave				
EFFICIENCY						
AC Mode		≥89% @ full charged battery		≥91% @ full charged battery		
ECO Mode		≥ 96% @ full charged battery				
Battery Mode		≥88%		≥90%		
BATTERY						
Battery Type		12V/7AH	12V/9AH	12V/9AH	12V/9AH	
Numbers		3	3	4	6	
Recharge Time		3 hours recover to 95% capacity for internal battery@ 2A charging current				
Charging Current		100/110/115/120 /127 VAC models: default 2A, max. 8A adjustable 200/208/220/230/240 VAC models: default 2A, max. 12A adjustable			Default: 2A, Max: 8Aadjustable	
Charging Voltage		41.0 VDC ± 1%	41.0 VDC ± 1%	54.7 VDC ± 1%	82.1 VDC ±1%	
PHYSICAL						
Dimension, D X W X H (in.)		16.5 x 17.25 x 3.5		20.5 x 17.25 x 3.5		24.8 x 17.25 x 3.5
Net Weight (lbs)		32	35	43	61	61
ENVIRONMENT						
Operation Humidity		20-95 % RH @ 0- 40°C (non-condensing)				
Noise Level		Less than 50dBA @ 1 Meter (With fan speed control)				
MANAGEMENT						
Smart RS-232 or USB		Supports Windows® 7/8/10/11, Linux, Unix and MAC				
Optional SNMP		Power management from SNMP manager and web browser				

Battery Pack Specification

Model	DC1000RTX1EBM	DC1500RTX1EBM	DC2000RTX1EBM	DC3000RTX1EBM
Used with UPS Models	DC1000RTX1	DC1500RTX1	DC2000RTX1	DC3000RTX1 DC3000RTX1HV
Battery Type	12V 7Ah	12V 9Ah	12V 9Ah	12V 9Ah
Battery Numbers	6	6	8	12
Dimensions (DxWxH) in.	16 x 17.5 x 3.5		19 x 17.5 x 3.5	24 x 17.5 x 3.5
Net Weight(lbs)	38	48	64	91

NOTE: Battery pack should be used with corresponded UPS.

Online RT1/RTX1 Runtime Chart (EBM only applies to RTX1 model)

Load (watts) / Time in minutes

Model	100	250	500	750	1000	1200	1500	2000	3000
DC1000RTX1	101	25	10	6	4	N/A	N/A	N/A	N/A
+ 1 EBM	393	128	53	31	20	N/A	N/A	N/A	N/A
+ 2 EBM	723	240	101	60	41	N/A	N/A	N/A	N/A
+ 3 EBM	1076	361	154	93	64	N/A	N/A	N/A	N/A
+ 4 EBM	1444	489	211	127	88	N/A	N/A	N/A	N/A
DC1500RTX1	139	43	17	9	6	5	3	N/A	N/A
+ 1 EBM	531	174	73	43	29	22	16	N/A	N/A
+ 2 EBM	973	325	140	83	57	45	33	N/A	N/A
+ 3 EBM	1444	488	211	128	89	70	52	N/A	N/A
+ 4 EBM	1935	659	288	175	122	97	73	N/A	N/A
DC2000RTX1	198	62	25	15	9	7	5	3	N/A
+ 1 EBM	748	248	105	63	43	34	22	17	N/A
+ 2 EBM	1364	460	199	120	84	66	45	34	N/A
+ 3 EBM	2019	688	300	182	128	101	70	52	N/A
+ 4 EBM	2700	926	407	248	175	139	97	73	N/A
DC3000RTX1	326	105	43	25	16	12	8	6	3
+ 1 EBM	1206	405	175	105	73	57	39	29	16
+ 2 EBM	2187	746	326	198	139	110	76	57	33
+ 3 EBM	3224	1110	489	299	211	168	117	88	52
+ 4 EBM	4302	1490	660	406	287	229	161	122	73

Call Orion Power Systems at 877-385-1654 for long runtime applications.

Orion Power Systems Service and Technical Support

If you have any problems or questions with the UPS, call your local distributor or Orion Power Systems technical support at the following telephone number:

In the United States: 1-877-385-1654

Please have the following information ready when you call:

- Model number and Serial number
- Description of failure or problem
- Date of failure or problem
- Customer contact information and return address

If repair is necessary, you will be given a Returned Material Authorization (RMA) number. The RMA number must appear on the outside of the box and on the Bill Of Lading. Original packaging should be used if available. Systems that get damaged in transit as a result of improper packaging are not covered under warranty. A replacement or repair unit will be shipped, freight prepaid for all units under warranty.

NOTE: For critical applications, immediate replacement may be available.

Product Registration

Product Registration is required to activate the load protection guarantee for your Orion Power UPS. Registering your product also allows Orion Power Systems to communicate product updates, features, and warranty issues.

Please register your product online at: <http://www.orionpowersystems.com/product-registration.html>