



Network Pro RTX2 User Manual

**Line Interactive Sinewave UPS
800 / 1.1K / 1.5K / 2K / 2.2K / 2.5K / 3K VA**

Uninterruptible Power Supply System

Version: 1.1

Table of Contents

1. Important Safety Warning.....	1
1-1. Transportation.....	1
1-2. Preparation	1
1-3. Installation.....	1
1-4. Operation	3
1-5. Maintenance, Service And Faults	3
2. Installation and Setup.....	7
2-1. Rear Panel View	7
2-2. Operating principle	8
2-3. Install The UPS	8
2-4. Setup The UPS	10
2-5 Battery Replacement	11
2-6 Battery Kit Assembly (option).....	12
3. Operations.....	15
3-1. Button Operation.....	15
3-2. LCD Panel	15
3-3. Audible Alarm	16
3-4. LCD Display Wordings Index	17
3-5. UPS Setting.....	17
3-6. Operating Mode Description	20
3-7. Faults Reference Code	22
3-8. Warning Indicator.....	23
4. Troubleshooting	24
5. Storage and Maintenance	25
5.1 Operation.....	25
5.2 Storage.....	25
6. Specifications.....	26

1. Important Safety Warning Avertissement de sécurité important

Please comply with all warnings and operating instructions in this manual strictly. Save this manual properly and read carefully the following instructions before installing the unit. Do not operate this unit before reading through all safety information and operating instructions carefully

Veillez vous conformer strictement à tous les avertissements et instructions d'utilisation de ce manuel. Conservez ce manuel correctement et lisez attentivement les instructions suivantes avant d'installer l'unité. N'utilisez pas cet appareil avant d'avoir lu attentivement toutes les informations de sécurité et les instructions d'utilisation.

1-1. Transportation Transport

- Please transport the UPS system only in the original package to protect against shock and impact. Veuillez transporter le système UPS uniquement dans son emballage d'origine pour le protéger des chocs et des potentiels contacts percutants.

1-2. Preparation Préparation

- Condensation may occur if the UPS system is moved directly from cold to warm environment. The UPS system must be absolutely dry before being installed. Please allow at least two hours for the UPS system to acclimate the environment.
De la condensation peut se produire si le système UPS est directement déplacé d'un environnement froid à un environnement chaud. Le système UPS doit absolument être sec avant d'être installé. Veuillez prévoir au moins deux heures pour que le système UPS s'acclimate à l'environnement.
- Do not install the UPS system near water or in moist environments. N'installez pas le système UPS près de l'eau ou dans des environnements humides.
- Do not install the UPS system where it would be exposed to direct sunlight or near heater. N'installez pas le système UPS ni où il pourrait être exposé à la lumière directe du soleil ni à côté d'un chauffage.
- Do not block ventilation holes in the UPS housing. Ne bloquez pas les trous de ventilation dans le boîtier de l'onduleur.

1-3. Installation

- Do not connect appliances or devices which would overload the UPS system (e.g. laser printers) to the UPS output sockets. · Ne connectez pas d'appareils ou de dispositifs susceptibles de surcharger le système UPS (par exemple, des imprimantes laser) aux prises de sortie UPS.
- Place cables in such a way that no one can step on or trip over them. · Placez les câbles de manière à ce que personne ne puisse marcher dessus ou trébucher dessus.
- Do not connect domestic appliances such as hair dryers to UPS output sockets. · Ne connectez pas d'appareils ménagers tels que des sèche-cheveux aux prises de sortie de l'onduleur.
- The UPS can be operated by any individuals with no previous experience. · L'onduleur peut être utilisé par toute personne même sans expérience préalable.
- Connect the UPS system only to an earthed shockproof outlet which must be easily accessible and close to the UPS system. · Connectez le système UPS uniquement à une prise antichoc mise à la terre qui doit être facilement accessible et proche du

système UPS.

- Please use only VDE-tested, CE-marked (or UL-marked for 100/110/115/120/127 VAC models) mains cable (e.g. the mains cable of your computer) to connect the UPS system to the building wiring outlet (shockproof outlet).
Veuillez utiliser uniquement un câble d'alimentation (par exemple le câble d'alimentation de votre ordinateur) homologué VDE, marqué CE (ou homologué UL pour les modèles 100/110/115/120/127 VAC) pour connecter le système UPS à la prise de câblage du bâtiment. (sortie antichoc).
- Please use only VDE-tested, CE-marked (or UL-marked for 100/110/115/120/127 VAC models) power cables to connect the loads to the UPS system. Veuillez utiliser uniquement des câbles d'alimentation testés VDE, marqués CE (ou UL pour les modèles 100/110/115/120/127 VAC) pour connecter les charges au système UPS.
- When installing the equipment, it should ensure that the sum of the leakage current of the UPS and the connected devices does not exceed 3.5mA. Lors de l'installation de l'équipement, il doit être assuré que la somme du courant de fuite de l'onduleur et des appareils connectés ne dépasse pas 3,5 mA.
- Temperature Rating - Units are considered acceptable for use in a maximum ambient of 40°C (104°F). Cote de température - Les unités sont considérées comme acceptables pour une utilisation dans une température ambiante maximale de 40 ° C (104 ° F).
- For PLUGGABLE EQUIPMENT, the socket-outlet shall be installed near the equipment and shall be easily accessible. Pour L'EQUIPEMENT ENFICHABLE, la prise de courant doit être installée près de l'équipement et doit être facilement accessible.
- CAUTION: The unit is heavy. Lifting the unit requires a minimum of two people. ATTENTION: L'unité est lourde. Le soulèvement de l'unité nécessite un minimum de deux personnes.
- Check if there is a protection device against over current and short circuit in the upstream of the UPS system. The recommended protection spec is 11A for 800VA~1100VA, 15A for 1.5KVA, 20A for LV 2KVA and 30A for 2.5~3KVA with a B or C trip curve. Vérifiez s'il existe un dispositif de protection contre les surintensités et les courts-circuits en amont du système UPS. La spécification de protection recommandée est de 11A pour 800VA ~ 1100VA, 15A pour 1,5KVA, 20A pour LV 2KVA et 30A pour 2,5 ~ 3KVA avec une courbe de déclenchement B ou C.

1-4. Operation - Opération

- Do not disconnect the mains cable on the UPS system or the building wiring outlet (shockproof socket outlet) during operations since this would cancel the protective earthing of the UPS system and of all connected loads. Ne débranchez pas le câble d'alimentation du système UPS ou de la prise de câblage du bâtiment (prise de courant antichoc) pendant les opérations car cela annulerait la protection par mise à la terre du système UPS et de toutes les charges connectées.
- The UPS system features its own, internal current source (batteries). The UPS output sockets or output terminals block may be electrically live even if the UPS system is not connected to the building wiring outlet. Le système UPS dispose de sa propre source de courant interne (batteries). Les prises de sortie de l'onduleur ou le bornier de sortie peuvent être sous tension, même si le système de l'onduleur n'est pas connecté à la prise de câblage du bâtiment.
- In order to fully disconnect the UPS system, first press the OFF/Enter button to disconnect the mains. Afin de complètement déconnecter le système UPS, appuyez d'abord sur le bouton OFF / Enter pour déconnecter le secteur.
- Prevent no fluids or other foreign objects from inside of the UPS system. Empêchez tout liquide ou autre corps étranger de pénétrer à l'intérieur du système UPS.
- The EPO, RS-232 and USB circuits are an IEC 60950-1 safety extra low voltage (SELV) circuit. This circuit must be separated from any hazardous voltage circuits by reinforced insulation. Les circuits EPO, RS-232 et USB sont des circuits de très basse tension de sécurité (TBTS) CEI 60950-1. Ce circuit doit être séparé de tout circuit de tension dangereux par une isolation renforcée.

1-5. Maintenance, Service And Faults - Maintenance, service et défauts

- The UPS system operates with hazardous voltages. Repairs may be carried out only by qualified maintenance personnel. Le système UPS fonctionne avec des tensions dangereuses. Les réparations ne peuvent être effectuées que par un personnel de maintenance qualifié.
- **Caution** - risk of electric shock. Even after the unit is disconnected from the mains (building wiring outlet), components inside the UPS system are still connected to the battery and electrically live and dangerous. **Attention** - risque de choc électrique. Même après que l'appareil soit déconnecté du secteur (prise de câblage du bâtiment), les composants à l'intérieur du système UPS sont toujours connectés à la batterie et sont sous tension électrique et dangereuse.
- Before carrying out any kind of service and/or maintenance, disconnect the batteries and verify that no current is present and no hazardous voltage exists in the terminals of high capability capacitor such as BUS-capacitors. Avant d'effectuer tout type de service et / ou de maintenance, débranchez les batteries et vérifiez qu'aucun courant n'est présent et qu'aucune tension dangereuse ne soit présente aux bornes des condensateurs à haute capacité tels que les condensateurs BUS.
- To avoid electrical shock, turn off the unit and unplug it from the AC power source before servicing the battery. Pour éviter les chocs électriques, éteignez l'appareil et débranchez-le de la source d'alimentation CA avant de réparer la batterie.
- Only persons who are adequately familiar with batteries and with the required precautionary measures may replace batteries and supervise operations. Unauthorized persons must be kept well away from the batteries. Seules les

personnes qui ont des connaissances suffisantes sur les batteries et les mesures de précaution requises peuvent remplacer les batteries et superviser les opérations. Les personnes non autorisées doivent être tenues à l'écart des batteries.

- **Caution** - risk of electric shock. The battery circuit is not isolated from the input voltage. Hazardous voltages may occur between the battery terminals and the ground. Before touching, please verify that no voltage is present! · **Attention** - risque de choc électrique. Le circuit de la batterie n'est pas isolé de la tension d'entrée. Des tensions dangereuses peuvent se produire entre les bornes de la batterie et la terre. Avant de toucher, veuillez vérifier qu'aucune tension n'est présente!
- Batteries may cause electric shock and have a high short-circuit current. Please take the precautionary measures specified below and any other measures necessary when working with batteries:
 - remove wristwatches, rings and other metal objects
 - use only tools with insulated grips and handles.Les batteries peuvent provoquer un choc électrique et avoir un courant de court-circuit élevé. Veuillez prendre les mesures de précaution spécifiées ci-dessous et toute autre mesure nécessaire lorsque vous travaillez avec des piles:
 - Retirer les montres-bracelets, bagues et autres objets métalliques
 - Utilisez uniquement des outils avec poignées isolées et poignées.
- When changing batteries, install the same number and same type of batteries. Lors du remplacement des piles, installez le même nombre et le même type de piles.
- Do not attempt to dispose of batteries by burning them. This could cause battery explosion. N'essayez pas de jeter les piles en les brûlant. Cela pourrait provoquer une explosion de la batterie.
- Do not open or destroy batteries. Escaping electrolyte can cause injury to the skin and eyes. It may be toxic. N'ouvrez pas et ne détruisez pas les piles. Une fuite d'électrolyte peut causer des blessures à la peau et aux yeux. Cela peut être toxique.
- When replacing batteries, use the same type and number of batteries or battery packs. Lors du remplacement des piles, utilisez le même type et le même nombre de piles ou de blocs-piles.

Manufacture	Type	Rated
Toplite (Guangzhou) Technology Battery Co Ltd (MH29104)	NPW45-12	12 V dc, 9.0 Ah
	UXW460-12	12 V dc, 9.0 Ah
	NPW36-12	12 V dc, 7.2 Ah
	UXW360-12	12 V dc, 7.2 Ah
	NPW45-12 FR	12 V dc, 7.0 Ah
	UXW460-12/FR	12 V dc, 7.0 Ah
	NPW36-12 FR	12 V dc, 7.0 Ah
	UXW360-12/FR	12 V dc, 7.0 Ah
CSB Battery Co Ltd (MH14533)	UPS 12460 F2	12 V dc, 9.0 Ah
	UPS 12360 6	12 V dc, 6.5 Ah
	UPS 12360 7	12 V dc, 6.5 Ah
	HR 1234W	12 V dc, 8.5 Ah
	HR 1234W FR	12 V dc, 8.5 Ah
Yuasa Battery (Guangdong) Co Ltd (MH29616)	NPW45-12	12 V dc, 8.0 Ah
	NPW45-12FR	12 V dc, 8.0 Ah

- Do not dismantle the UPS system. Ne démontez pas le système UPS.
- A battery can may cause a risk of electrical shock and high short-circuit current. Une batterie peut entraîner un risque de choc électrique et de courant de court-circuit élevé.

The following precautions should be observed when working on batteries:

- Remove watches, rings, or other metal objects.
- Use tools with insulated handles.
- Wear rubber gloves and boots.
- Do not lay tools or metal parts on top of batteries.
- Disconnect charging source prior to connecting or disconnecting battery terminals.
- Determine if battery is inadvertently grounded. If inadvertently grounded, remove source from ground. Contact with any part of a grounded battery can result in electrical shock. The likelihood of such shock can be reduced if such grounds are removed during installation and maintenance.

Les précautions suivantes doivent être observées lorsque vous travaillez avec des batteries:

- Retirez les montres, bagues ou autres objets métalliques.
- Utilisez des outils avec des poignées isolées.
- Portez des gants et des bottes en caoutchouc.
- Ne posez pas d'outils ou de pièces métalliques sur les batteries.
- Déconnectez la source de charge avant de connecter ou de déconnecter les bornes de la batterie.
- Déterminez si la batterie est mise à la terre par inadvertance. En cas de mise à la terre par inadvertance, retirez la source de la terre. Le contacte avec n'importe quelle partie d'une batterie mise à la terre peut provoquer un choc électrique. La probabilité d'un tel choc peut être réduite si ces motifs sont supprimés lors de l'installation et de la maintenance.

- **WARNING:** This is a category C2 UPS product. In a residential environment, this

product may cause radio interference, in which case the user may be required to take additional measures. (only for 220/230/240 VAC system)

AVERTISSEMENT: Il s'agit d'un onduleur de catégorie C2. Dans un environnement résidentiel, ce produit peut provoquer des interférences radio, auquel cas l'utilisateur peut être amené à prendre des mesures supplémentaires. (uniquement pour le système 220/230/240 VAC)

FCC Compliance Statement

This equipment has been tested and found to comply with the limits for a Class B digital device, pursuant to Part 15 of the FCC rules. These limits are designed to provide reasonable protection against harmful interference in a residential installation. This equipment generates, uses, and can radiate radio frequency energy and, if not installed and used in accordance with the instructions, may cause harmful interference to radio communications.

However, there is no guarantee that interference will not occur in a particular installation. If this equipment does cause interference to radio and television reception, which can be determined by turning the equipment off and on, the user is encouraged to try to correct the interference by one or more of the following measures:

- Reorient or relocate the receiving antenna
- Increase the separation between the equipment and the receiver
- Connect the equipment into an outlet on a circuit different from that to which the receiver is connected.
- Consult the dealer or an experienced radio/TV technician for help.

WARNING: Changes or modifications not expressly approved by the manufacturer could void the user's authority to operate the equipment.

Déclaration de conformité FCC

Cet équipement a été testé et déclaré conforme aux limites d'un appareil numérique de classe B, conformément à la partie 15 des règles de la FCC. Ces limites sont conçues pour fournir une protection raisonnable contre les interférences nuisibles dans une installation résidentielle. Cet équipement génère, utilise et peut émettre de l'énergie de radiofréquence et, s'il n'est pas installé et utilisé conformément aux instructions, peut provoquer des interférences nuisibles aux communications radio.

Cependant, il n'y a aucune garantie qu'aucune interférence ne se produira dans une installation particulière. Si cet équipement provoque des interférences avec la réception radio et télévision, ce qui peut être déterminé en éteignant puis en rallumant l'équipement, l'utilisateur est encouragé à essayer de corriger les interférences par une ou plusieurs des mesures suivantes:

- Réorientez ou déplacez l'antenne de réception
- Augmenter la distance entre l'équipement et le récepteur
- Connectez l'équipement à une prise sur un circuit différent de celui auquel le récepteur est connecté.
- Consultez le revendeur ou un technicien radio / TV expérimenté pour obtenir de l'aide.

AVERTISSEMENT: Les changements ou modifications non expressément approuvés par le fabricant peuvent annuler le droit de l'utilisateur à utiliser l'équipement.

2. Installation and Setup

NOTE: Before installation, please inspect the unit. Be sure that nothing inside the package is damaged. Please keep the original package in a safe place for future use. Avant l'installation, veuillez inspecter l'unité. Assurez-vous que rien à l'intérieur de l'emballage n'est endommagé. Veuillez conserver l'emballage d'origine dans un endroit sûr pour une utilisation future.

2-1. Rear Panel View

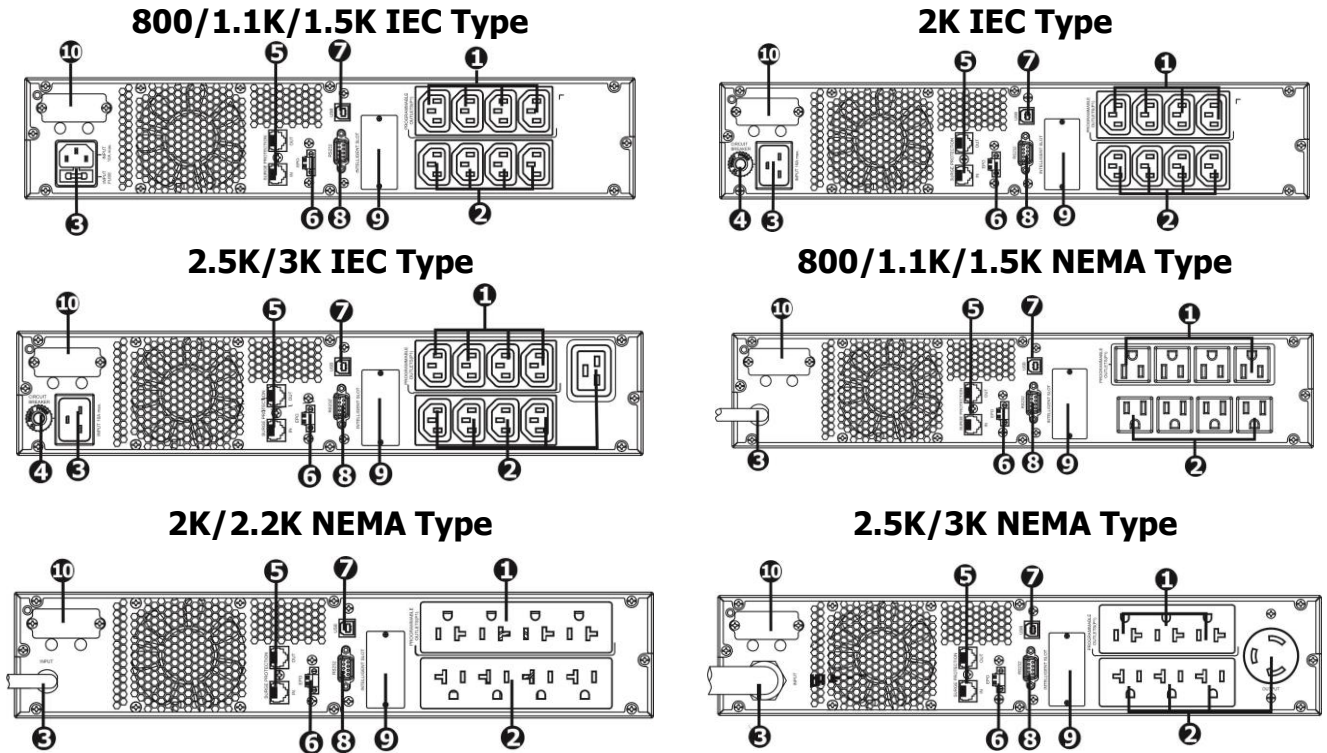

1. Programmable outlets: connect to non-critical loads.
2. Output receptacles: connect to mission-critical loads.
3. AC input
4. Input circuit breaker
5. Network/Fax/Modem surge protection
6. Emergency power off function connector (EPO)
7. USB communication port
8. RS-232 communication port
9. SNMP intelligent slot
10. External battery connector

2-2. Operating principle

The operating principle of the UPS is shown as below.

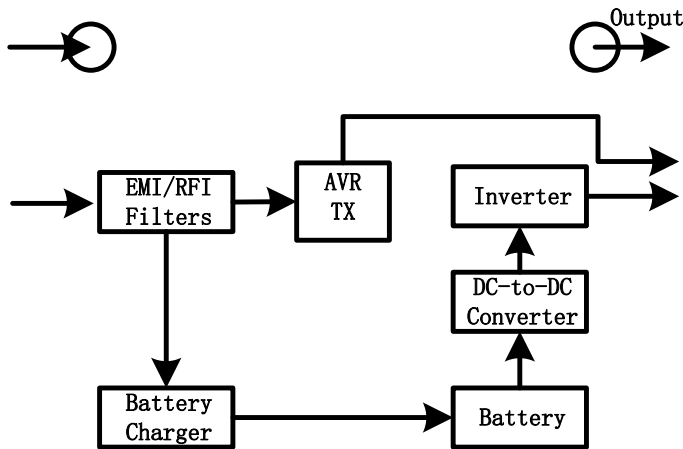

The UPS is composed of mains input, EMI/RFI Filters, Inverter, Battery charger, DC-to-DC converter, battery, AVR TX and UPS output

2-3. Install The UPS

For safety consideration, the UPS is shipped out from factory without connecting the battery wires. Before installing the UPS, please follow below steps to re-connect battery wires first.

Step 1

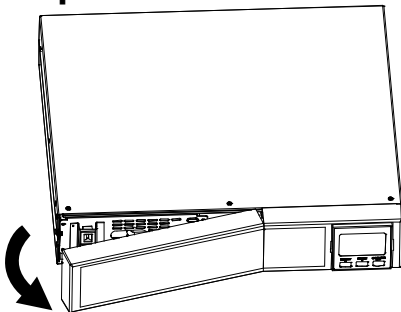

Remove front panel.

Step 2

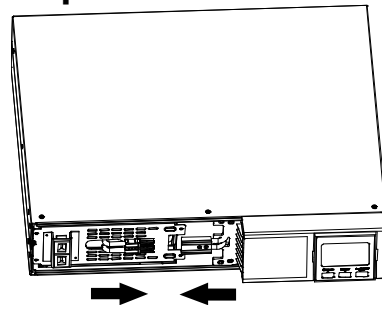

Connect the AC input and re-connect battery wires.

Step 3

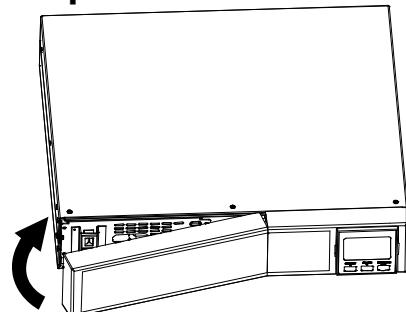

Put the front panel back to the unit.

Rack-mount Installation

CAUTION – Do NOT use the mounting brackets to lift the unit. The mounting brackets are only for securing the unit to the rack. Use optional PN# OPS-Railkit to support rear of UPS in 4 post racks and enclosures.

ATTENTION - N'utilisez PAS les supports de montage pour soulever l'appareil. Les supports de montage servent uniquement à fixer l'unité aux supports de poteaux. Utilisez le PN # OPS-Railkit facultatif pour prendre en charge l'arrière de l'onduleur dans les 4 supports de poteaux et boîtiers.

Install UPS alone

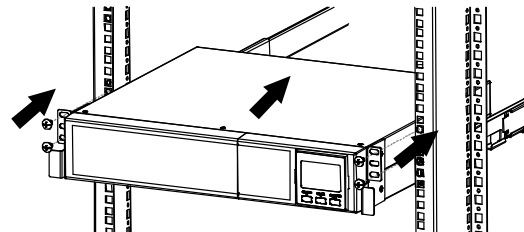
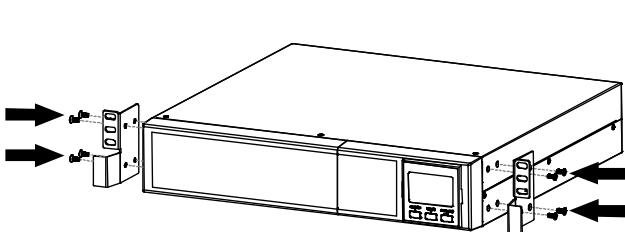

Install UPS and external battery

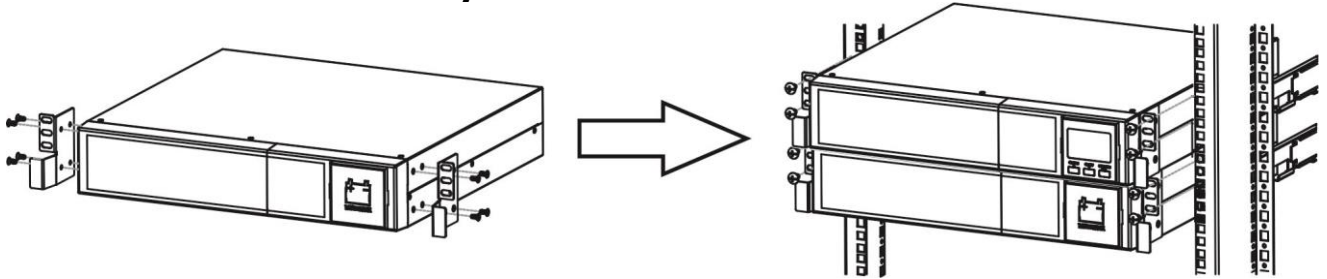

Tower Installation

Install UPS alone

Step 1

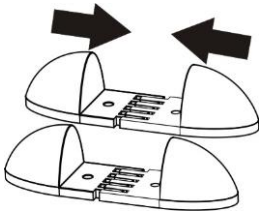

Step 2

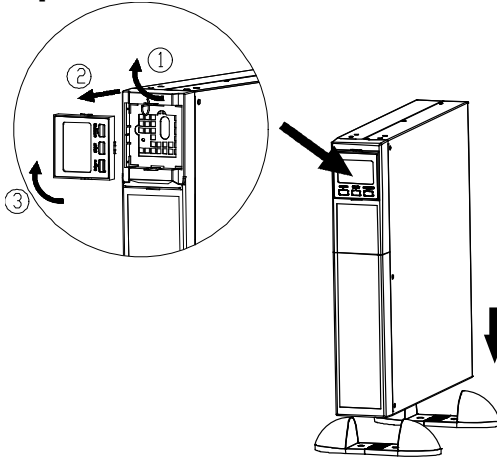

Step 3

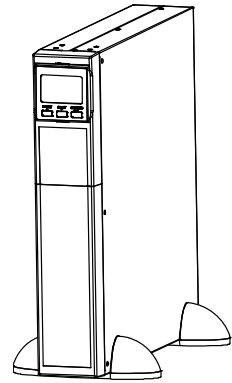

Install UPS and external battery

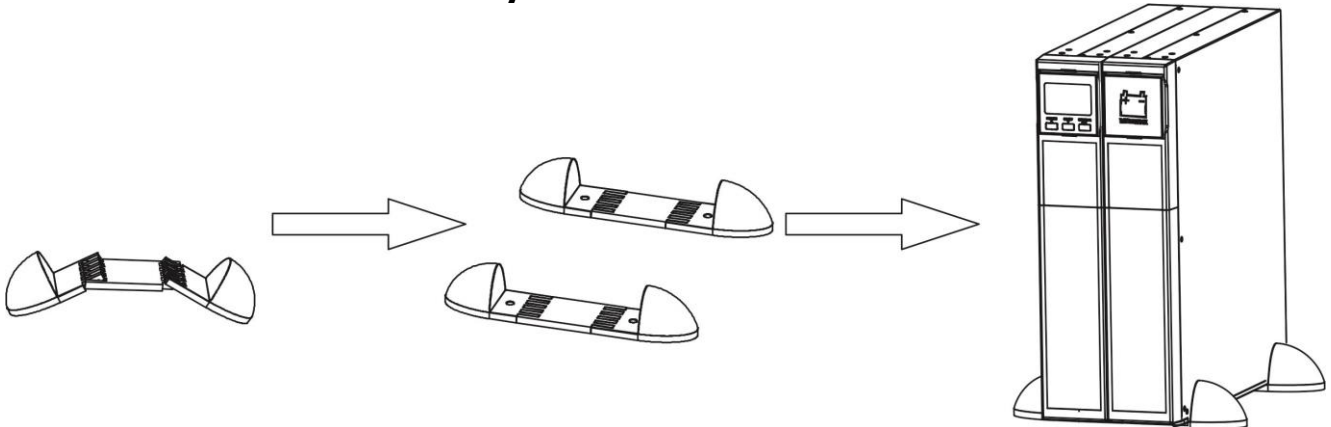

NOTE: When installing the UPS or battery pack with feet, please keep 70mm distance from the edge of the unit.

REMARQUE: Lors de l'installation de l'onduleur ou de la batterie avec des pieds, veuillez garder une distance de 70 mm du bord de l'unité.

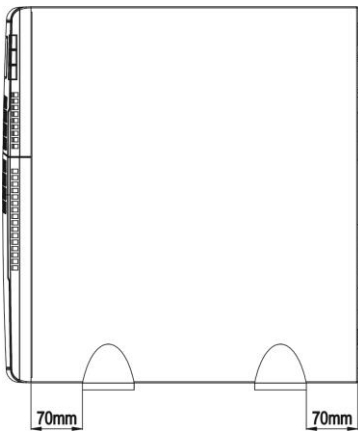

2-4. Setup The UPS

Step 1: UPS input connection

Plug the UPS into a two-pole, three-wire, grounded receptacle only. Avoid using extension cords.

Step 2: UPS output connection

There two kinds of outputs: programmable outlets and general outlets. Please connect non-critical devices to the programmable outlets and critical devices to the general outlets. During power failure, you may extend the backup time to critical devices by setting shorter backup time for non-critical devices.

Step 3: Communication connection

Communication ports:

USB port



RS-232 port

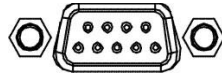

Intelligent slot



To allow for unattended UPS shutdown/start-up and status monitoring, connect one end of communication cable to the USB/RS-232 port and the other to the communication port of your PC. With the monitoring software installed, you can schedule UPS shutdown/start-up and monitor UPS status through PC.

The UPS is equipped with intelligent slot perfect for either SNMP or AS400 card. When installing either SNMP or AS400 card in the UPS, it will provide advanced communication and monitoring options.

PS. USB port and RS-232 port can't work at the same time.

Step 4: Network connection

Network/Fax/Phone surge port



Connect a single modem/phone/fax line into surge-protected "IN" outlet on the back panel of the UPS unit. Connect from "OUT" outlet to the equipment with another modem/fax/phone line cable.

Step 5: Disable and enable EPO function

This UPS is equipped with EPO function. By default, the UPS is delivered from factory with Pin 1 and pin 2 closed (a metal plate is connected to Pin 1 and Pin2) for UPS normal operation. To activate EPO function, remove two screws on EPO port and green connector will be removed.

Note: The EPO function logic can be set up via LCD setting. Please refer to program 16 in UPS setting for the details.

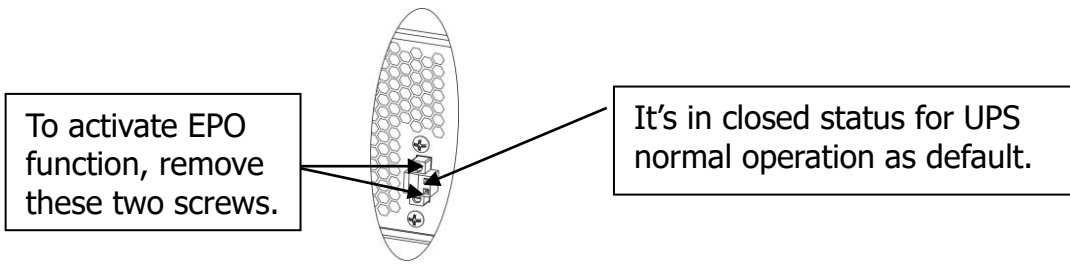

Step 6: External battery connection

Connect one end of external battery cable to UPS unit and the other end to battery box. Use the chart below for detailed connection.

CAUTION: Connection to External Battery shall be installed by SERVICE PERSONNEL only.

ATTENTION: La connexion à la batterie externe doit être installée uniquement par le PERSONNEL DE SERVICE.

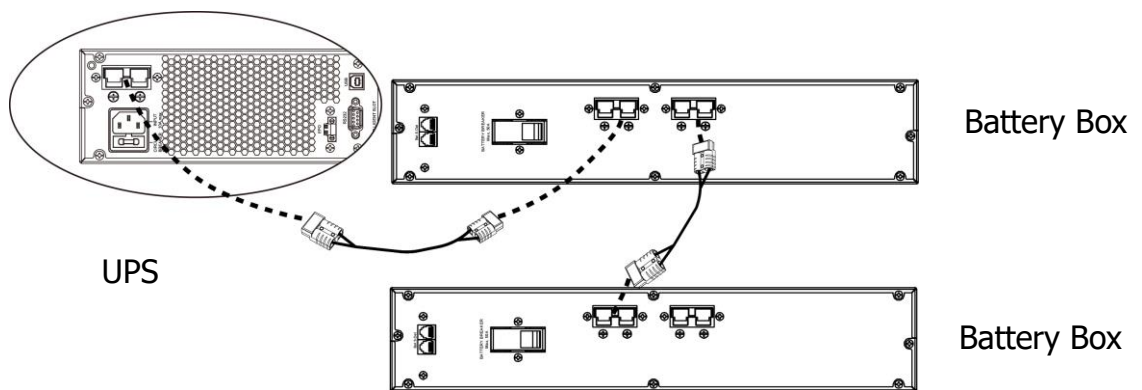

NOTE: If connecting more one external battery box, it's requested to connect load at 80% of UPS capacity.

Step 7: Turn on the UPS

Press the ON/Mute button on the front panel for two seconds to power on the UPS.

Note: The battery charges fully during the first five hours of normal operation. Do not expect full battery run capability during this initial charge period.

Step 8: Install software

For optimal computer system protection, install UPS monitoring software to fully configure UPS shutdown. Please follow steps below to download and install monitoring software:

1. Go to the website:

<https://www.orionpowersystems.com/software-downloads.html>

2. Click ViewPower software icon and then choose your required OS to download the software.

3. Follow the on-screen instructions to install the software.

4. When your computer restarts, the monitoring software will appear as an orange plug icon located in the system tray, near the clock.

2-5 Battery Replacement

NOTICE: This UPS is equipped with internal batteries and only service person can replace the batteries.

AVIS: Cet onduleur est équipé de batteries internes et seul un technicien peut remplacer les batteries.

CAUTION!! Consider all warnings, cautions, and notes before replacing batteries.

Note: Upon battery disconnection, equipment is not protected from power outages.

MISE EN GARDE!! Tenez compte de tous les avertissements, mises en garde et consignes avant de remplacer les piles.

Remarque: Lors de la déconnexion de la batterie, l'équipement n'est pas protégé contre les coupures de courant.

Step 1

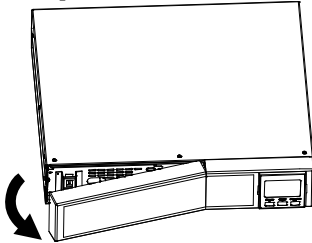

Remove front panel.

Step 2

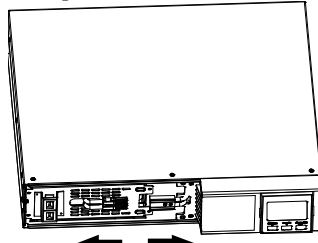

Disconnect battery wires.

Step 3

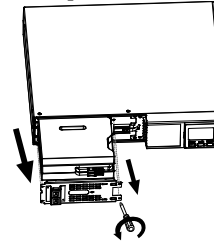

Pull out the battery box by removing two screws on the front panel.

Step 4

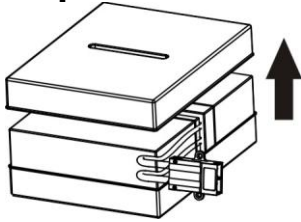

Remove the top cover of battery box and replace the inside batteries.

Step 5

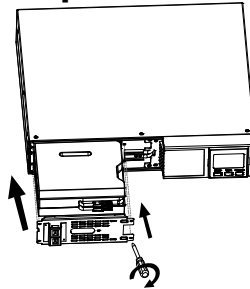

After replacing the batteries, put the battery box back to original location. Put the front panel back to the unit and install screws.

Step 7

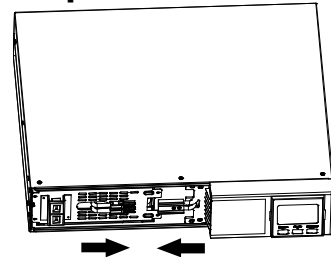

Re-connect the battery wires.

Step 8

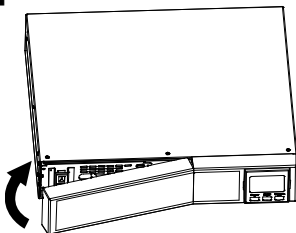

2-6 Battery Kit Assembly (option)

NOTICE: Please assemble battery kit first before installing it inside of UPS. Please select correct battery kit procedure below to assemble it.

AVIS: Veuillez assembler le kit de batterie avant de l'installer à l'intérieur de l'onduleur. Veuillez sélectionner la procédure de kit de batterie appropriée ci-dessous pour l'assembler.

2-battery kit

Step 1: Remove adhesive tapes.

Step 2: Connect all battery terminals by following below chart.

Tapes

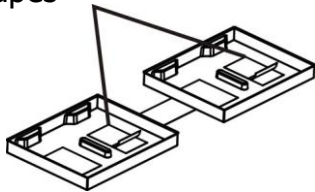

Step 3: Put assembled battery packs on one side of plastic shells.

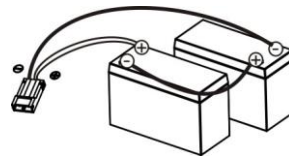

Step 4: Cover the other side of plastic shell as below chart. Then, battery kit is assembly well.

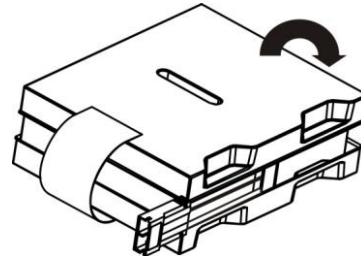
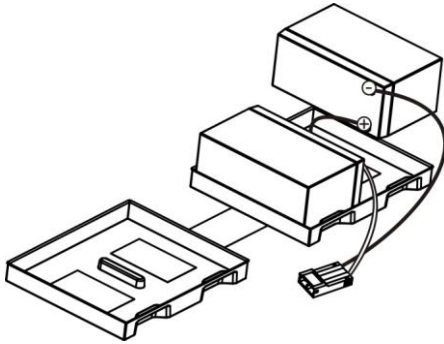

4-battery kit

Step 1: Remove adhesive tapes.

Step 2: Connect all battery terminals by following below chart.

Tapes

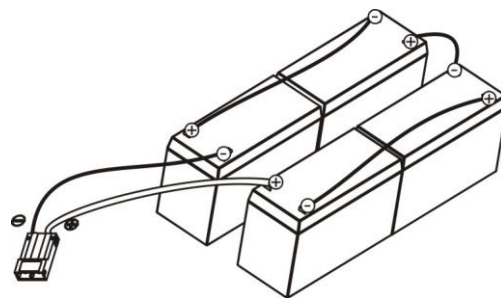
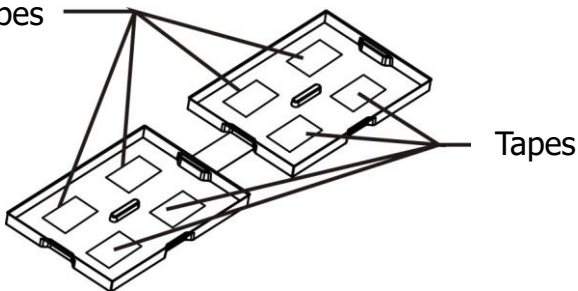

Step 3: Put assembled battery packs on one side of plastic shells.

Step 4: Cover the other side of plastic shell as below chart. Then, battery kit is assembly well.

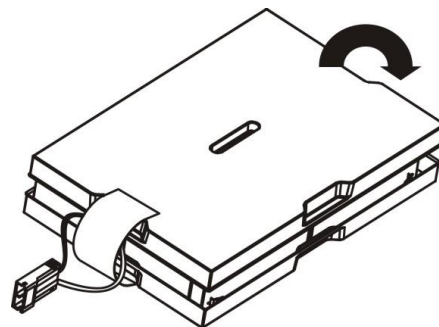
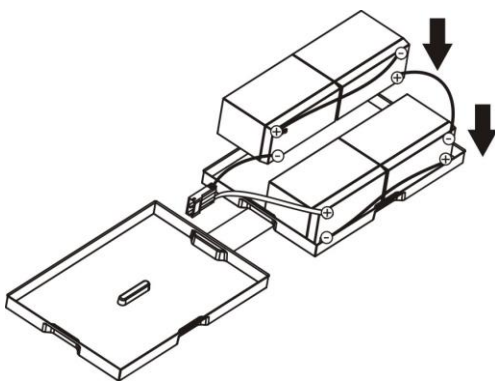

6-battery kit

Step 1: Remove adhesive tapes.

Step 2: Connect all battery terminals by following below chart.

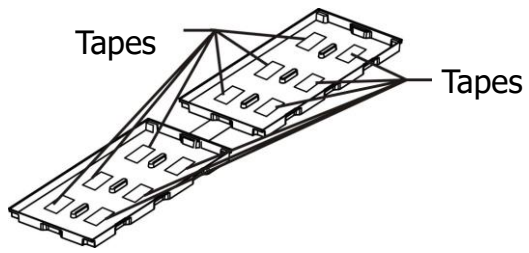

Step 3: Put assembled battery packs on one side of plastic shells.

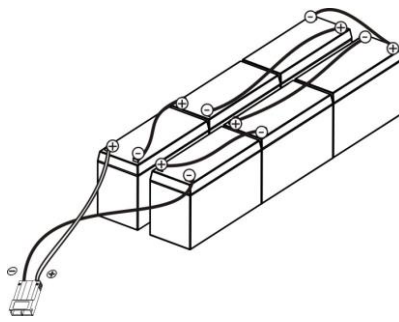
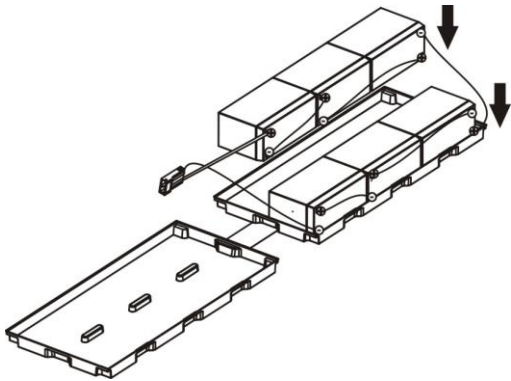

Step 4: Cover the other side of plastic shell as below chart. Then, battery kit is assembly well.

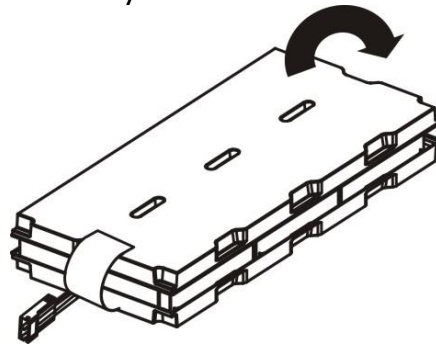

3. Operations









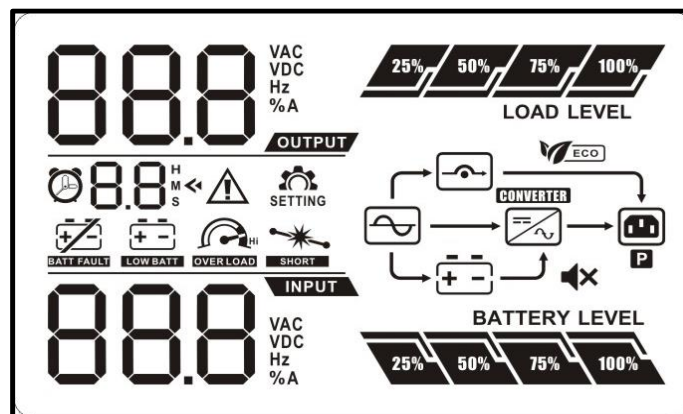





3-1. Button Operation



Button	Function
ON/MUTE Button	<ul style="list-style-type: none"> ➤ Turn on the UPS: Press and hold ON/Mute button for at least 2 seconds to turn on the UPS. ➤ Mute the alarm: After the UPS is turned on in battery mode, press and hold this button for at least 3 seconds to disable or enable the alarm system. But it's not applied to the situations when warnings or errors occur. ➤ Up key: Press this button to display previous selection in UPS setting mode. ➤ Switch to UPS self-test mode: Press and hold ON/Mute button for 3 seconds to enter UPS self-testing while in AC mode
OFF/ENTER Button	<ul style="list-style-type: none"> ➤ Turn off the UPS: Press and hold this button at least 2 seconds to turn off the UPS ➤ Confirm selection key: Press this button to confirm selection in UPS setting mode.
SELECT Button	<ul style="list-style-type: none"> ➤ Switch LCD message: Press this button to change the LCD message for input voltage, input frequency, battery voltage, output voltage and output frequency. ➤ Setting mode: Press and hold this button for 3 seconds to enter UPS setting mode when UPS is off. ➤ Down key: Press this button to display next selection in UPS setting mode.
Select + OFF/Enter Button	<ul style="list-style-type: none"> ➤ Rack or Tower display switch: Press Select and OFF/Enter buttons simultaneously for 3 seconds. The display change from/to Rack to/from Tower.

3-2. LCD Panel

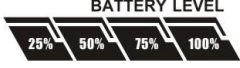

Display	Function
Backup time information	
 8.8 ^H _M _S	Indicates the estimated backup time. H: hours, M: minute
Configuration and fault information	
8.8 <	Indicates the configuration items, and the configuration items are listed in details in section 3-5.
8.8 < 	Indicates the warning and fault codes, and the codes are listed in details in section 3-7 and 3-8.
Output information	
88.8 ^{VAC} _{VDC} _{Hz} _{%A} OUTPUT	Indicates the output voltage and output frequency. V: voltage, Hz: frequency
Load information	
 25% 50% 75% 100% LOAD LEVEL	Indicates the load level by 0-24%, 25-49%, 50-74%, and 75-100%.
 OVER LOAD	Indicates overload.
 SHORT	Indicates the load or the UPS output is short circuited.
Programmable outlets information	
	Indicates that programmable management outlets are working.
Mode operation information	
	Indicates the UPS connects to the mains.
	Indicates the battery is working.
	Indicates the bypass circuit is working.
	Indicates the ECO mode is enabled.
	Indicates the inverter circuit is working.
	Indicates the output is working.
	Indicates that the UPS alarm is disabled.
Battery information	
 BATTERY LEVEL 25% 50% 75% 100%	Indicates the Battery level by 0-24%, 25-49%, 50-74%, and 75-100%.
 BATT FAULT	Indicates the battery is fault.
 LOW BATT	Indicates low battery level and low battery voltage.
Input & Battery voltage information	
88.8 ^{INPUT} _{VAC} _{VDC} _{Hz} _{%A}	Indicates the input voltage, input frequency and battery voltage. Vac: Input voltage, Vdc: battery voltage, Hz: input frequency

3-3. Audible Alarm

Battery Mode	Sounding every 10 seconds
Low Battery	Sounding every 2 seconds
Overload	Sounding every second
Fault	Continuously sounding

3-4. LCD Display Wordings Index

Abbreviation	Display content	Meaning
ENA	ENR	Enable
DIS	dI S	Disable
ESC	ESC	Escape
ON	ON	ON
OK	OK	OK
EP	EP	EPO
AO	AO	Active open
AC	AC	Active close
TP	tP	Temperature
CH	CH	Charger
RAC	RAC	Rack display
TOE	tOE	Tower display
SF	SF	Site Fault
EE	EE	EEPROM error
BR	bR	Battery Replacement

3-5. UPS Setting

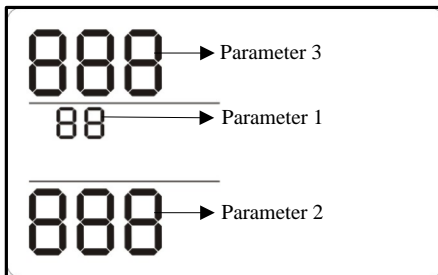

There are two parameters to set up the UPS.

Parameter 1: It's for program alternatives. Refer to below table for details.

Parameter 2: It's setting options or values for each program.

● 01: Output voltage setting

Interface	Setting
	<p>For 208/220/230/240 VAC models, you may choose the following output voltage:</p> <ul style="list-style-type: none"> 208: presents output voltage is 208Vac 220: presents output voltage is 220Vac 230: presents output voltage is 230Vac (Default) 240: presents output voltage is 240Vac <p>For 110/115/120/127 VAC models, you may choose the following output voltage:</p> <ul style="list-style-type: none"> 110: presents output voltage is 110Vac 115: presents output voltage is 115Vac 120: presents output voltage is 120Vac (Default) 127: presents output voltage is 127Vac

● 02: Programmable outlets enable/disable

Interface	Setting
	ENA: Programmable outlets enable (Default) DIS: Programmable outlets disable

● 03: Programmable outlets setting

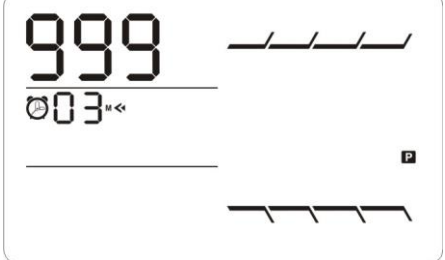
Interface	Setting
	Setting the backup time limits in minutes from 0-999 for programmable outlets which connect to non-critical devices on battery mode.

● 04: Maximum charger current setting

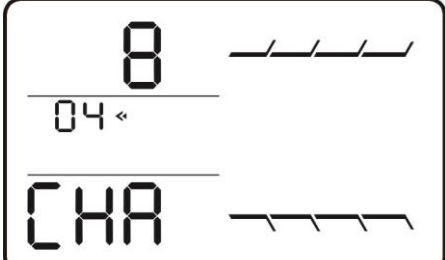
Interface	Setting
	Set up the maximum charger current. 1/2/4/6/8: setting the maximum charger current at 1/2/4/6/8 Ampere. (Default: 8A) Note: This setting is only effective for super charger.

● 06: Autonomy limitation setting

Interface	Setting
	Parameter 2: Set up backup time on battery mode for general outlets. 0-999: setting the backup time in minutes from 0-999 for general outlets on battery mode. DIS: Disable the autonomy limitation and the backup time will depend on battery capacity. (Default) Note: When setting as "0", the backup time will be only 10 seconds.

● 07: Battery total AH setting

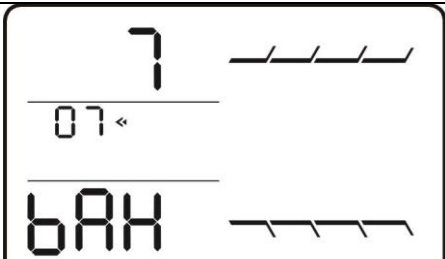
Interface	Setting
	Parameter 2: Set up the battery total AH of the UPS. 7-999: setting the battery total capacity from 7-999 in AH. Please set the correct battery total capacity if external battery bank is connected. To calculate total AH, use Chart A

Steps for setting runtime calculation (Chart A)

Battery AH Chart	AH Rating
NP800RTX2	7AH
NP1100RTX2	9AH
NP1500RTX2	7AH
NP2000RTX2	9AH
NP2200RTX2	7AH
NP2500RTX2	7AH
NP3000RTX2	9AH
NP1100RTX2EBM	18AH
NP2000RTX2EBM	18AH
NP3000RTX2EBM	18AH

The LCD screen runtime calculation is defaulted to internal batteries. To setup the LCD runtime calculator when adding EBMs, you must change the parameter 07: Battery total AH setting (see above). The total battery AH setting equals the internal battery AH rating plus the sum of the AH rating of the EBMs. For example, an NP2000RTX2 with (2) NP2000RTX2EBM would have a total AH rating of 45AH.

- 08: EPO logic setting

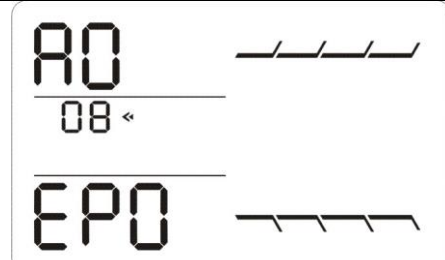
Interface	Setting
	<p>Set up the EPO function control logic.</p> <p>AO: Active Open (Default). When AO is selected as EPO logic, it will activate EPO function with Pin 1 and Pin 2 in open status.</p> <p>AC: Active Close. When AC is selected as EPO logic, it will activate EPO function with Pin 1 and Pin 2 in close status.</p>





- 00: Exit setting

Steps for setting programmable outlet

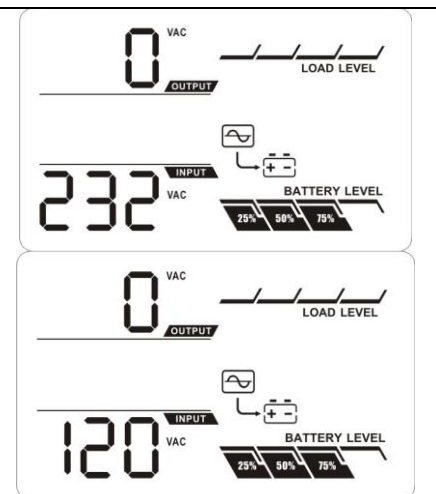
Step 1:

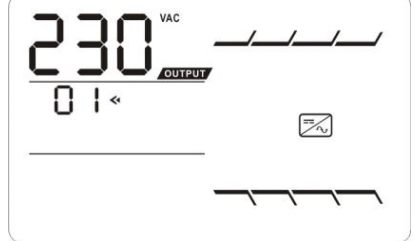
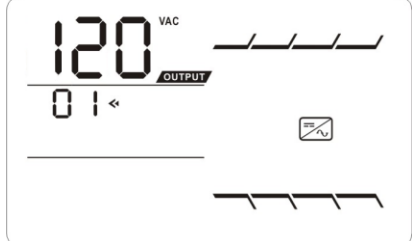
Before entering setting mode, the UPS should be in Stand-by mode (off-charging) and make sure the battery is connected. The LCD display is shown as right.

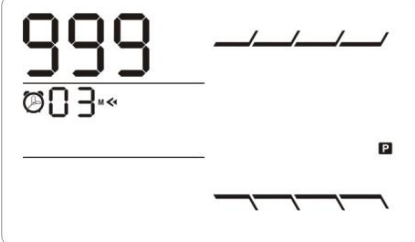

<p>Step 2: Press and hold the "Selection" button for 3 seconds to enter Setting mode.</p>	 
<p>Step 3: Press the "Up" button (ON/MUTE) to switch to "02" of program list. Then press "Enter" button to enter value setting of parameter 2. Press the "Up" button to change the value to "ENA" to enable the programmable outlet function. Then press "Enter" button again to confirm the setting.</p>	
<p>Step 4: Press the "Up" button (ON/MUTE) again to switch to "03" of program list. Then press "Enter" button for setting programmable outlet time. Push "Up" button to change the value of backup time according your demand. Then press "Enter" to confirm the setting.</p>	
<p>Step 5: Press "Up" button (ON/MUTE) to switch to "00" of program list. Then press "Enter" button to exit setting menu.</p>	
<p>Step 6: Disconnect AC input and wait until the LCD display is off. The new setting will be activated when turning on the UPS again.</p>	



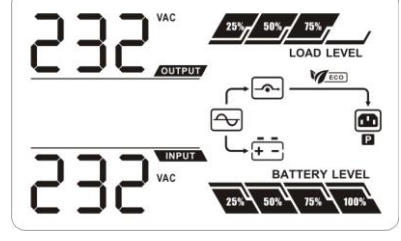

3-6. Operating Mode Description

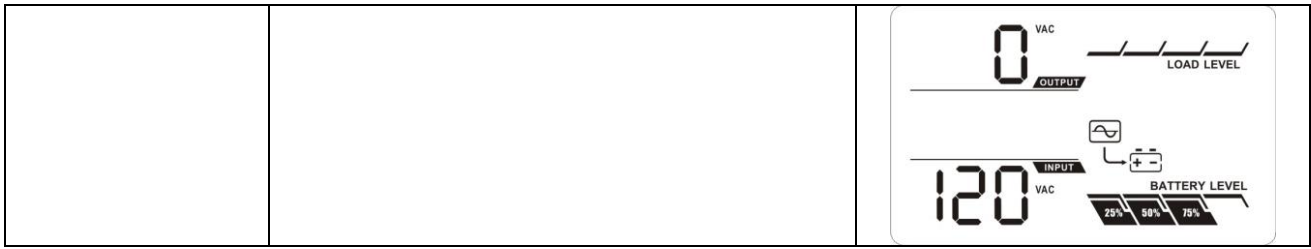
Operating mode	Description	LCD display
ECO mode	When the input voltage is within voltage regulated range, UPS will power the output directly from the mains. ECO is an abbreviation of Efficiency Corrective Optimizer. In this mode, when battery is fully charged, the fan will stop working for energy saving.	

















		<p>The display shows 120 VAC OUTPUT and 120 VAC INPUT. The LOAD LEVEL is at 25% and the BATTERY LEVEL is at 25%. The diagram shows power flowing from the AC input through the AVR to the output, with the battery as a backup.</p>
Buck mode when AC is normal.	When the input voltage is higher than the voltage regulation range but lower than high loss point, the buck AVR will be activated.	<p>The display shows 219 VAC OUTPUT and 255 VAC INPUT. The LOAD LEVEL is at 25% and the BATTERY LEVEL is at 25%. The diagram shows the buck AVR circuit activated to step down the input voltage.</p>
Boost mode when AC is normal.	When the input voltage is lower than the voltage regulation range but higher than low loss point, the boost AVR will be activated.	<p>The display shows 116 VAC OUTPUT and 135 VAC INPUT. The LOAD LEVEL is at 25% and the BATTERY LEVEL is at 25%. The diagram shows the boost AVR circuit activated to step up the input voltage.</p>
Battery mode	When the input voltage is beyond the acceptable range or power failure and alarm is sounding every 10 seconds, UPS will backup power from battery.	<p>The display shows 232 VAC OUTPUT and 200 VAC INPUT. The BATTERY LEVEL is at 25%. The battery voltage is shown as 72.0 VDC. The diagram shows the UPS operating in battery mode, with power drawn from the battery to supply the load.</p>
Battery mode	When the input voltage is beyond the acceptable range or power failure and alarm is sounding every 10 seconds, UPS will backup power from battery.	<p>The display shows 120 VAC OUTPUT and 72.0 VDC BATTERY LEVEL. A timer shows 4.8 minutes remaining. The diagram shows the UPS operating in battery mode.</p>
Standby mode	UPS is powered off and no output supply power, but still can charge batteries.	<p>The display shows 0 VAC OUTPUT and 232 VAC INPUT. The BATTERY LEVEL is at 25%. The diagram shows the UPS in standby mode, with the AC input connected to the battery charging circuit.</p>



3-7. Faults Reference Code











Fault event	Fault code	Icon	Fault event	Fault code	Icon
Bus start fail	01	x	Inverter output short	14	
Bus over	02	x	Battery voltage too high	27	
Bus under	03	x	Battery voltage too low	28	
Inverter soft start fail	11	x	Over temperature	41	X
Inverter voltage high	12	x	Over load	43	
Inverter voltage Low	13	x	Charger failure	45	X

3-8. Warning Indicator

Warning	Icon (flashing)	Alarm
Low Battery	 	Sounding every 2 seconds
Overload	 	Sounding every second
Battery is not connected	 	Sounding every 2 seconds
Over Charge	 	Sounding every 2 seconds
Site wiring fault	 	Sounding every 2 seconds
EPO enable	 EP	Sounding every 2 seconds
Over temperature	 TP	Sounding every 2 seconds
Charger failure	 CH	Sounding every 2 seconds
Battery fault	 	Sounding every 2 seconds (At this time, UPS is off to remind users of something wrong with battery)
EEPROM error	 EE	Sounding every 2 seconds
Battery replacement	 BT	Sounding every 2 seconds

4. Troubleshooting

If the UPS system does not operate correctly, please solve the problem by using the table below.

Symptom	Possible cause	Remedy
No indication and alarm even though the mains is normal.	The AC input power is not connected well.	Check if input power cord firmly connected to the mains.
	The AC input is connected to the UPS output.	Plug AC input power cord to AC input correctly.
The icon  and the warning code EP flashing on LCD display and alarm is sounding every 2 seconds.	EPO function is activated.	Set the circuit in close position to disable EPO function.
The icon  and  flashing on LCD display and alarm is sounding every 2 seconds.	Line and neutral conductors of UPS input are reversed.	Rotate mains power socket by 180° and then connect to UPS system.
The icon  and  flashing on LCD display and alarm is sounding every 2 seconds.	The external or internal battery is incorrectly connected.	Check if all batteries are connected well.
Fault code is shown as 27 and the icon  is lighting on LCD display and alarm is continuously sounding.	Battery voltage is too high or the charger is fault.	Contact your dealer.
Fault code is shown as 28 and the icon  is lighting on LCD display and alarm is continuously sounding.	Battery voltage is too low or the charger is fault.	Contact your dealer.
The icon  and the icon  are flashing on LCD display and alarm is sounding every second.	UPS is overload	Remove excess loads from UPS output.
Fault code is shown as 43 and The icon  is lighting on LCD display and alarm is continuously sounding.	The UPS shut down automatically because of overload at the UPS output.	Remove excess loads from UPS output and restart it.
Fault code is shown as 14 and alarm is continuously sounding.	The UPS shut down automatically because short circuit occurs on the UPS output.	Check output wiring and if connected devices are in short circuit status.

Symptom	Possible cause	Remedy
Fault code is shown as 01, 02, 03, 11, 12, 13 and 41 on LCD display and alarm is continuously sounding.	A UPS internal fault has occurred.	Contact your dealer
Battery backup time is shorter than nominal value	Batteries are not fully charged	Charge the batteries for at least 5 hours and then check capacity. If the problem still persists, consult your dealer.
	Batteries defect	Contact your dealer to replace the battery.
Fault code is shown as 45 on LCD display. At the same time, alarm is continuously sounding.	The charger does not have output and battery voltage is less than 10V/PC.	Contact your dealer.

5. Storage and Maintenance

5.1 Operation

The UPS system contains no user-serviceable parts. If the battery service life (3~5 years at 25°C ambient temperature) has been exceeded, the batteries must be replaced. In this case, please contact your dealer.



Be sure to deliver the spent battery to a recycling facility or ship it to your dealer in the replacement battery packing material.

5.2 Storage

Before storing, charge the UPS 5 hours. Store the UPS covered and upright in a cool, dry location. During storage, recharge the battery in accordance with the following table:

Storage Temperature	Recharge Frequency	Charging Duration
-25°C - 40°C	Every 3 months	1-2 hours
40°C - 45°C	Every 2 months	1-2 hours

6. Specifications

MODEL	NP800RTX2	NP1100RTX2	NP1500RTX2	NP2000RTX2	NP2200RTX2	NP2500RTX2	NP3000RTX2
CAPACITY	800 VA / 720 W	1100 VA / 990 W	1500 VA / 1350 W	2000 VA / 1800 W	2000 VA / 2000 W	2500 VA / 2250 W	3000 VA / 2700 W
INPUT							
Acceptable Voltage Range	81-145 VAC or 162-290 VAC						
Frequency Range	60/50 Hz (auto sensing)						
Line Cord	5-15P			5-20P	5-20P	L5-30P	
OUTPUT							
Voltage Reg. (AC Mode)	110/115/120/127 VAC or 208/220/230/240 VAC						
Voltage Reg. (Batt. Mode)	±1.5%(before battery alarm)						
Frequency Range (Batt. Mode)	50 Hz or 60 Hz ± 1 Hz						
Current Crest Ratio	3:1						
Harmonic Distortion	2% max @ 100% linear load, 5% max @ 100% non-linear load (before low battery alarm)						
Transfer Time	Typical 2-6 ms, 10ms max.						
Waveform (Batt. Mode)	Pure Sine Wave						
Receptacles	(8) 5-15R			(8) 5-20R	(8) 5-20R	(6) 5-20R (1) L5-30R	
EFFICIENCY							
AC Mode	95% for 110/115/120/127 VAC ; 97% for 208/220/230/240 VAC						
Buck & Boost Mode	93% for 110/115/120/127 VAC ; 95% for 208/220/230/240 VAC						
Battery Mode	88% for 110/115/120/127 VAC 89% for 208/220/230/240 VAC	90% for 110/115/120/127 VAC 91% for 208/220/230/240 VAC			90% for 110/115/120/127 VAC 92% for 208/220/230/240 VAC		
BATTERY							
Battery Type & Number	12 V/7 Ahx2	12 V/9 Ahx2	12 V/7 Ahx4	12 V/9 Ahx4	12 V/7 Ahx6	12 V/7 Ahx6	12 V/9 Ahx6
Charging Voltage	27.4 VDC ± 1%		54.8 VDC ± 1%		82.1 VDC ± 1%		
Recharge Time	4 hours recover to 90% capacity						
PROTECTION							
Full Protection	Overload, short, discharge, and overcharge protection						
ALARM							
Battery Mode	Sounding every 10 seconds						
Low Battery	Sounding every 2 seconds						
Overload	Sounding every second						
Battery Replacement Alarm	Sounding every 2 seconds						
Fault	Continuously sounding						
PHYSICAL							
Dimension, DXWXH (in.)	17 x 17.2 x 3.5		21 x 17.2 x 3.5		24.8 x 17.2 x 3.5		
Net Weight (lbs.)	29	30	43	48	61	61	65
ENVIRONMENT							
Operating Humidity	0-90 % RH @ 0- 40°C (non-condensing)						
Noise Level	Less than 45dB						
MANAGEMENT							
Smart RS-232/USB	Supports Windows® 2000/2003/XP/Vista/2008, 7/8, Linux, Unix, and MAC						
Optional SNMP	Power management from SNMP manager and web browser						
APPROVALS	TUV (UL1778) FCC , Class B Part 15						

* Derate capacity to 80% of capacity when the output voltage is adjusted to 208VAC.

**Product specifications are subject to change without further notice.

*** NP800RTX2, NP1100RTX2, NP2500RTX2, and 220V IEC models are non-stock special order.

Battery Pack Specification

Model	NP1100RTX2EBM	NP2000RTX2EBM	NP3000RTX2EBM
Used with UPS Models	NP1100RTX2	NP2000RTX2	NP3000RTX2
Battery Type	12V 9Ah	12V 9Ah	12V 9Ah
Battery Numbers	4	8	12
Dimensions (DxWxH)	15 x 17.2 x 3.5	19 x 17.2 x 3.5	24 x 17.2 x 3.5
Net Weight (lbs)	38	64	91

NOTE: Battery pack should be used with corresponded UPS.

NP1100RTX2EBM is used with NP800RTX2 and NP1100RTX2.

NP2000RTX2EBM is used with NP1500RTX2 and NP2000RTX2.

NP3000RTX2EBM is used with NP2200RTX2, NP2500RTX2, and NP3000RTX2.

When more than 1 set of external battery pack is used (or battery capacity is more than 18AH), please reduce the connected load to 80% of UPS capacity.

Network Pro RTX2 Runtime Chart

Model	Load (watts) / Time in minutes								
	100	250	500	750	1000	1200	1350	1800	2700
NP800RTX2	60	17	6.5	N/A	N/A	N/A	N/A	N/A	N/A
+ 1 EBM	303	97	39.5	N/A	N/A	N/A	N/A	N/A	N/A
+ 2 EBM	579	190	80.5	N/A	N/A	N/A	N/A	N/A	N/A
+ 3 EBM	874	292	123.5	N/A	N/A	N/A	N/A	N/A	N/A
+ 4 EBM	1183	398	171.5	N/A	N/A	N/A	N/A	N/A	N/A
NP1100RTX2	83	25	10	5	N/A	N/A	N/A	N/A	N/A
+ 1 EBM	326	105	43	25	N/A	N/A	N/A	N/A	N/A
+ 2 EBM	602	198	84	50	N/A	N/A	N/A	N/A	N/A
+ 3 EBM	897	300	127	77	N/A	N/A	N/A	N/A	N/A
+ 4 EBM	1206	406	175	105	N/A	N/A	N/A	N/A	N/A
NP1500RTX2	154	49	20	12	7	6	5	N/A	N/A
+ 1 EBM	704	235	100	60	41	33	28	N/A	N/A
+ 2 EBM	1320	447	194	117	82	65	56	N/A	N/A
+ 3 EBM	1975	675	295	179	126	100	86	N/A	N/A
+ 4 EBM	2656	913	402	245	173	138	120	N/A	N/A
NP2000RTX2	198	62	25	15	9	7	6	4	N/A
+ 1 EBM	748	248	105	63	43	34	29	20	N/A
+ 2 EBM	1364	460	199	120	84	66	57	39	N/A
+ 3 EBM	2019	688	300	182	128	101	87	60	N/A
+ 4 EBM	2700	926	407	248	175	139	121	84	N/A
NP2200/2500RTX2	240	77	31	17	12	9	8	5	N/A
+ 1 EBM	1160	377	163	97	69	54	38	29	N/A
+ 2 EBM	2141	718	314	190	135	107	75	57	N/A
+ 3 EBM	3178	1082	477	291	207	165	116	88	N/A
+ 4 EBM	4256	1462	648	398	283	226	160	122	N/A
NP3000RTX2	326	105	43	25	16	12	8	6	3.7
+ 1 EBM	1206	405	175	105	73	57	39	29	19
+ 2 EBM	2187	746	326	198	139	110	76	57	39
+ 3 EBM	3224	1110	489	299	211	168	117	88	61
+ 4 EBM	4302	1490	660	406	287	229	161	122	84

Call Orion Power Systems at 877-385-1654 for long runtime applications.

Orion Power Systems Service and Technical Support

If you have any problems or questions with the UPS, call your local distributor or Orion Power Systems technical support at the following telephone number:

In the United States: 1-877-385-1654

Please have the following information ready when you call:

- Model number and Serial number
- Description of failure or problem
- Date of failure or problem
- Customer contact information and return address

If repair is necessary, you will be given a Returned Material Authorization (RMA) number. The RMA number must appear on the outside of the box and on the Bill Of Lading. Original packaging should be used if available. Systems that get damaged in transit as a result of improper packaging are not covered under warranty. A replacement or repair unit will be shipped, freight prepaid for all units under warranty.

NOTE: For critical applications, immediate replacement may be available.

Product Registration

Product Registration is required to activate the load protection guarantee for your Orion Power UPS. Registering your product also allows Orion Power Systems to communicate product updates, features, and warranty issues.

Please register your product online at:

<http://www.orionpowersystems.com/product-registration.html>